

morbidelli range

cx100/cx110/cx210/cx220

CNC drilling centres





MORBIDELLI CX

FROM OUR EXPERIENCE
TO YOUR DRILLING EXPERTISE

morbidelli range cx100/cx110/cx210/cx220

CNC drilling centres

morbidelli cx100



morbidelli cx110



morbidelli cx210/cx220



EASY, INTELLIGENT, COMPACT

6
RANGE

8
cx 100

16
cx 110

24
cx210/CX220

COMPACT



Maximum technology at your fingertips: best space/performance ratio.

TOP QUALITY



Unrivalled drilling precision with the new RO.AX technology (Rotoaxial spindle technology), the most efficient spindle on the market with rotation speed up to 8000 rpm.

FASTER



No set-up: no manual intervention on the machine thanks to the workpiece handling by clamps. Ideal for **batch 1 production**.

FLEXIBLE



Not only drilling: different machinings for multiple needs.

Customisation in the operating units and **integration** according to different demands.

DIGITAL



Simple, fast and reliable management with the **Maestro Suite's** wide range of software and the **integrated industrial PC** with multi-touch display.

32

PANEL LOADING-UNLOADING

34

OVERALL DIMENSIONS

36

TECHNICAL DATA

RANGE

EASY, INTELLIGENT, COMPACT: DIFFERENT SOLUTIONS FOR ALL NEEDS

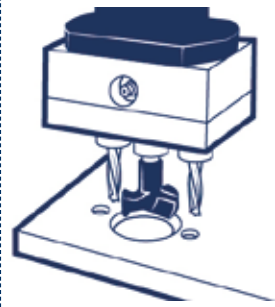

MODEL	WORKING AREA ALONG X, Y, Z MIN./MAX.	DRILLING	ROUTING WITH TOOL CHANGE	HINGES
morbidelli cx100	X 200 / 3050 Y 70 / 900 Z 10 / 60	F18L	X	X
morbidelli cx110	X 200 / 3050 Y 50 / 950 Z 8 / 60	F19L or F23L	6 POSITIONS	AGGREGATE
morbidelli cx210/cx220	X 200 / 3050 Y 50 / 1300 Z 8 / 95	F31LTC (cx210) F31LTC + F21L (cx220)	6 POSITIONS	✓

li CX

morbidelli range cx100/cx110/cx210/cx220

CNC drilling centres

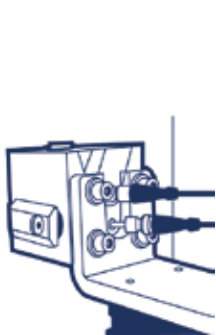

SLIDING

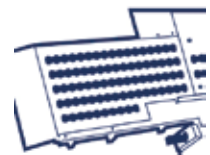

ROLLERS

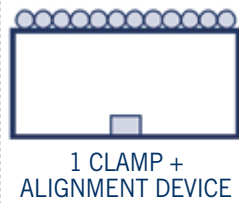

1 CLAMP +
ALIGNMENT DEVICE



2 CLAMPS



COPYING SYSTEM	WORK TABLE	HANDLING SYSTEM	LAMELLO	DOWELING	INTEGRATION
X	SLIDING	1 CLAMP + ALIGNMENT DEVICE	X	X	X
X, Y, Z	ROLLERS	1 CLAMP + ALIGNMENT DEVICE	✓	X	✓
X, Y, Z	ROLLERS	2 CLAMPS	✓	✓	✓

TECHNICAL FEATURES OVERVIEW

DETAILS THAT MAKE THE DIFFERENCE



Maximum piece stability and high machining quality, thanks to the mobile clamp with floating opening that does not require any adjustment.



Ergonomic: the side supports allow the operator to easily load and unload panels up to 3050 mm.



Safety and reliability, thanks to the upper presser unit which ensures the adherence of the pieces to the lower reference, guaranteeing maximum machining precision.

morbidelli cx100

CNC drilling centres



Highly precise and fast movements: all the machining units are driven by brushless motors, sliding along prismatic guides with recirculating balls supports.

PRODUCTIVE, FLEXIBLE, VERSATILE

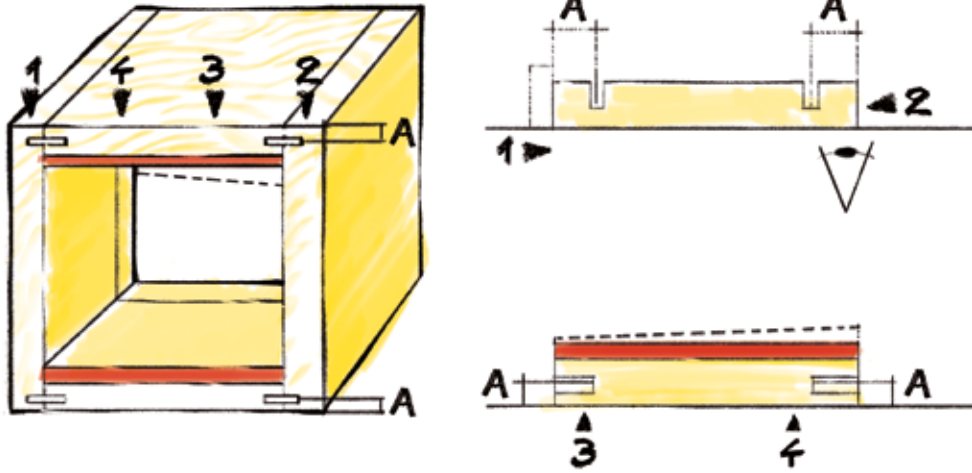

PERFECT FINISH:

the position of the operating unit in relation to the work table allows for a flawless finish, even on various panel thicknesses.



COMPLETE EQUIPMENT OF THE MACHINING UNIT:

with drilling head for vertical and horizontal holes, blade for grooves along X axis and routing motor up to 5.5 kW at 18000 rpm.





VERY SHORT MACHINING CYCLES AND ZERO DOWN TIMES:

for set-up operations; drilling head with 18 independent spindles (12 verticals, 4 horizontals along X axis, 2 horizontals along Y axis) and blade along X axis covering the whole surface of the panel, to machine:

- length from 200 to 3050 mm
- height from 70 to 900 mm
- thickness from 10 to 60 mm

HIGHLY PRECISE AND FAST MOVEMENTS:

all the machining units are driven by brushless motors, sliding along prismatic guides with recirculating ball leads. The displacement along X, Y, and Z is guaranteed through highly precise recirculating ball screws.



PRODUCTIVE, FLEXIBLE, VERSATILE

MAXIMUM SET-UP SPEED:

with the ISO 30 fast tool change. Easy and safe replacement of the tool.

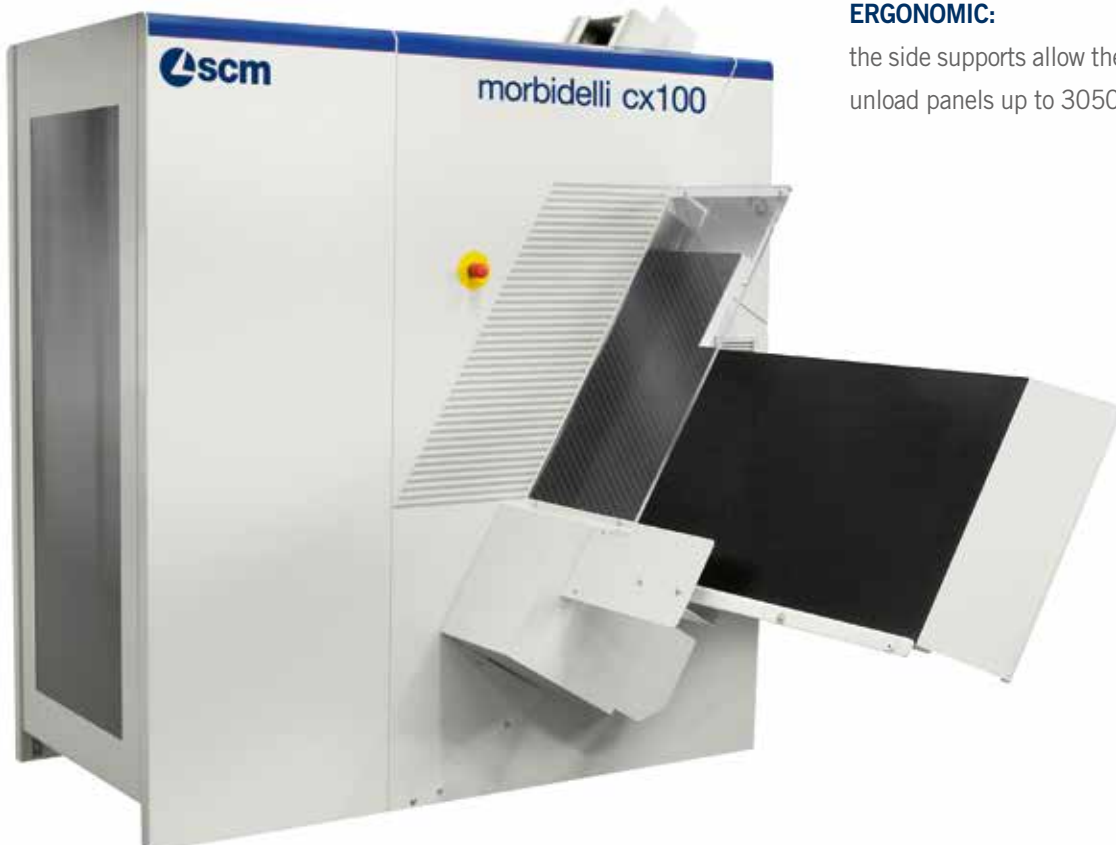
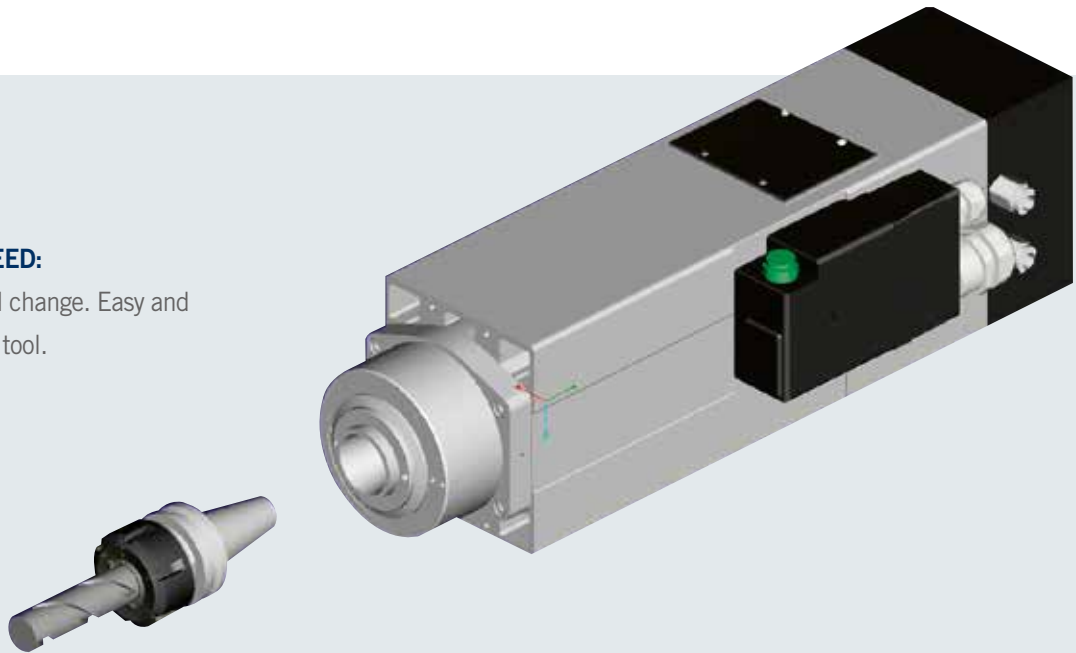

ERGONOMIC:

the side supports allow the operator to easily load and unload panels up to 3050 mm.

MAXIMUM PIECE STABILITY:

with the floating opening clamp that does not require any adjustment and high machining quality with the Bakelite non-scratch table, also ideal for delicate surfaces. Zero imprecision in horizontal drilling thanks to pressure devices.



HIGHLY VERSATILE:

the **programmable side reference stop** allows to machine pieces with dowels already inserted or with routing already carried out.

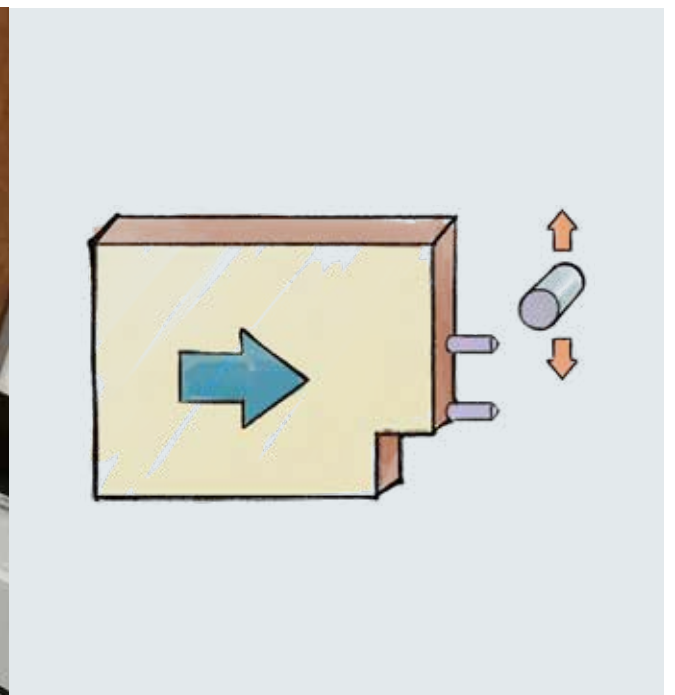

PRODUCTIVE, FLEXIBLE, VERSATILE



SAFETY AND RELIABILITY:

thanks to the upper presser unit which ensures the adherence of the workpieces to the lower reference, guaranteeing maximum machining precision.

The dust extraction hoods allow perfect cleaning of the workpieces.

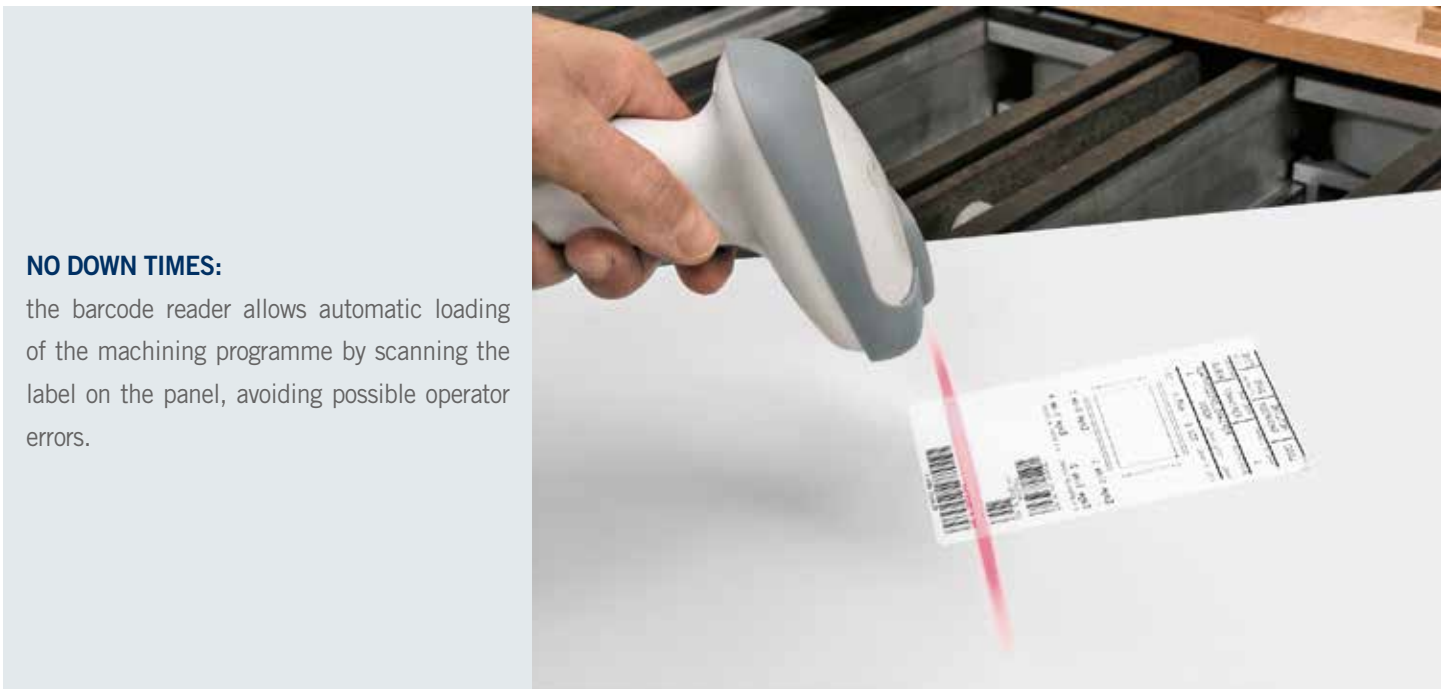

NO DOWN TIMES:

the barcode reader allows automatic loading of the machining programme by scanning the label on the panel, avoiding possible operator errors.

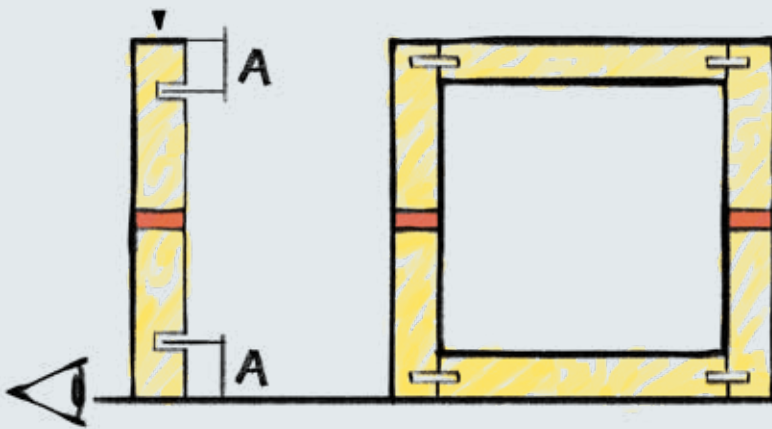

PERFECT JOINTS

with the automatic reading of the piece length. Any difference between the actual length of the panel and the length set is detected by the highly precise laser reader, ensuring perfect alignment.

POSSIBILITY OF LOCAL ROUTINGS ALONG THE WHOLE PANEL:

- blade cutting along X direction
- machining of panels with **delicate surfaces**
- **rounding** on four edges
- **Toe-Kick** machining

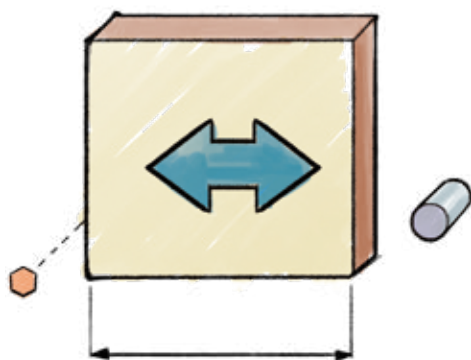

EXECUTING PROGRAMS:

with right and left or mixed reference using the rear sensor.

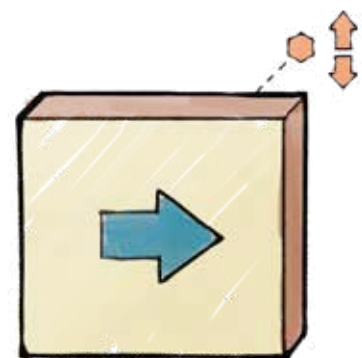

NO PANEL LOADING ERRORS:

with the **Y congruence sensor** checking that the size of the panel inserted matches the size programmed.

cx110

TECHNICAL FEATURES OVERVIEW

DETAILS THAT MAKE THE DIFFERENCE



High flexibility with all the required tools always available on board thanks to the **6-positions automatic tool changer**.



No scratches thanks to the work table capable of processing lacquered and delicate panels.

Maximum stability of the workpiece thanks to lower bearings and pressed by upper side-alignment device, moved in x with cnc clamp.

morbidelli cx110

CNC drilling centres



Extreme precision thanks to the 3D PROBE decimal copying system with four sensors.



Not only drills: device for "Clamex" type connections.



No repositioning, and faster machining cycles thanks to the shaped clamp, able to execute any type of drilling.

PRODUCTIVE, FLEXIBLE, VERSATILE

TAYLOR-MADE: CUSTOM DRILLING

Possibility of two different drilling heads.

F19L:

- 13 vertical spindles
- 4 horizontal spindles along X
- 2 horizontal spindles along Y

F23L:

- 113 vertical spindles
- 6 horizontal spindles along X
- 4 horizontal spindles along Y

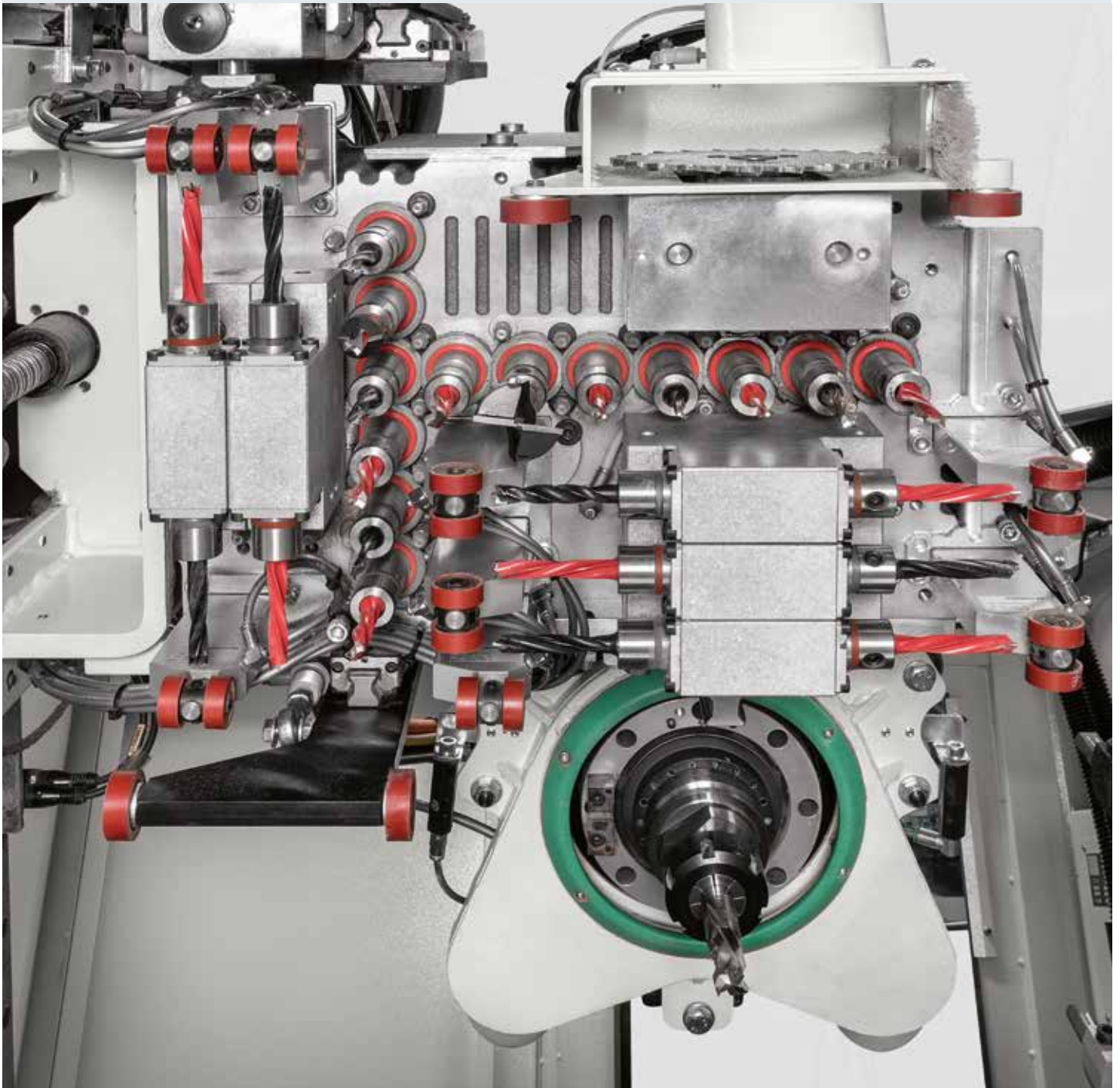



QUALITY AT THE HEART: PERFECT DRILLING

Mounted on the drilling heads, **RO.AX spindles** with rotation speeds of **up to 8000 rpm** guarantee the highest quality finish and fastest drilling.

HINGE DRILLING: THE THREE IN ONE SOLUTION!

Possibility of carrying out 3 simultaneous drillings with a single head.



PRODUCTIVE, FLEXIBLE, VERSATILE

HIGHLY FUNCTIONAL AND RELIABLE

- HSK63F 7,5kW electrospindle
- 1500/24.000 rpm
- with dust extraction hood and pressure ring to ensure the workpiece position and maximum cleanliness during machining.



Power - Torque S6

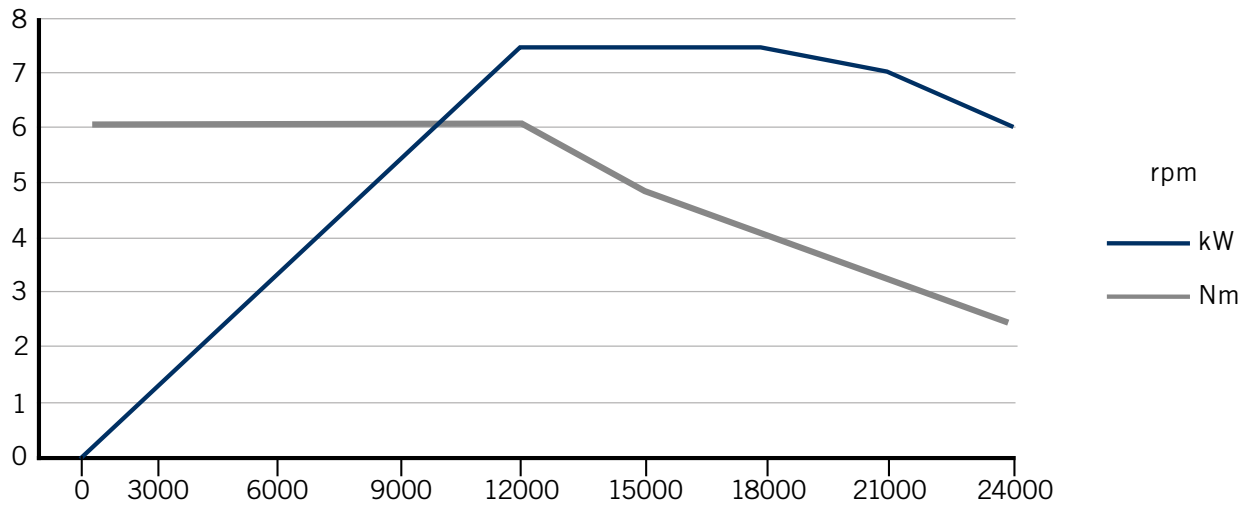

EXTREME PRECISION

thanks to the 3D PROBE decimal copying system with four sensors.



HIGH FLEXIBILITY

with all the required tools always available on board thanks to the 6-positions automatic tool changer.



NOT ONLY DRILLS:

aggregate for "Chamex" type connections.

PRODUCTIVE, FLEXIBLE, VERSATILE

NO SCRATCHES

thanks to the work table capable of processing lacquered and delicate panels.

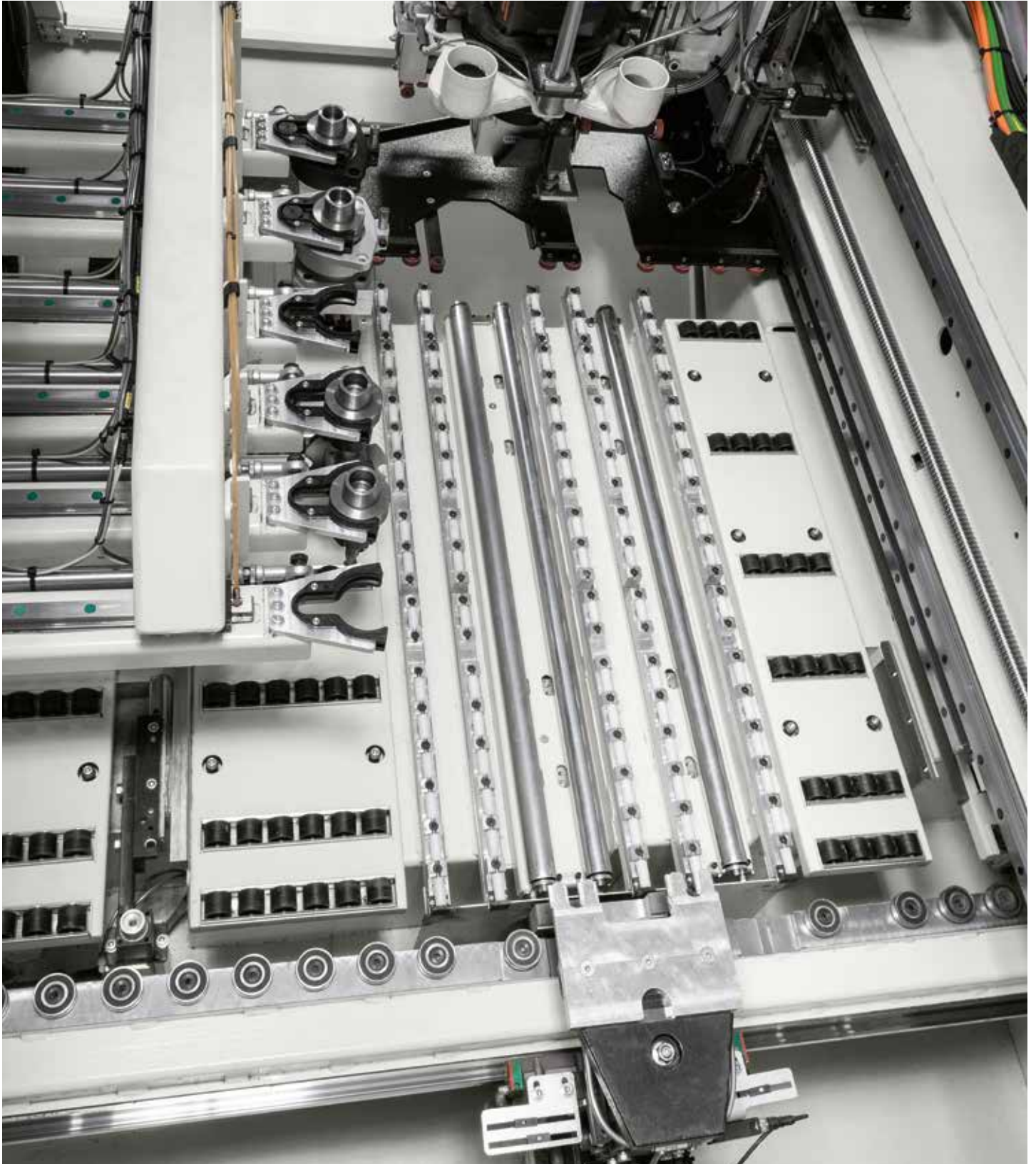

NON-STOP MACHINING CYCLE

Shaped clamp to execute any machining **without repositioning**.



MAXIMUM STABILITY OF THE WORKPIECE

thanks to lower bearings and pressed by upper side-alignment device, moved in x with cnc clamp.

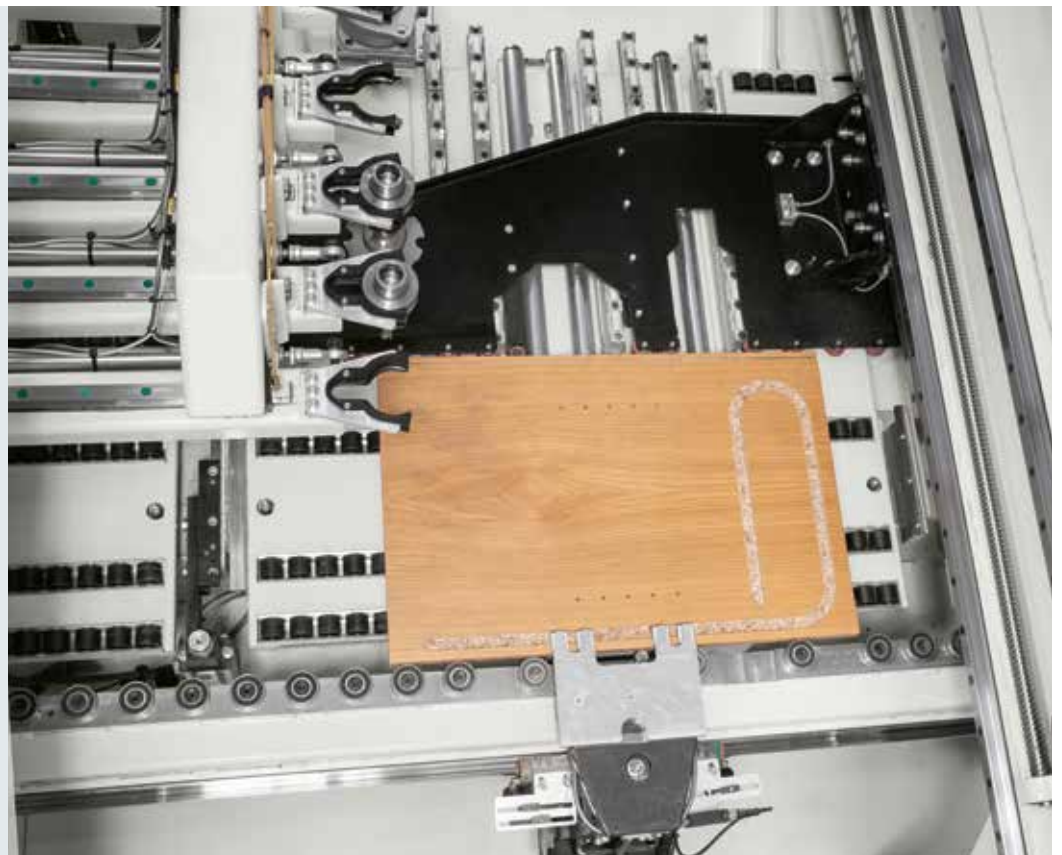

TECHNICAL FEATURES OVERVIEW

DETAILS THAT MAKE THE DIFFERENCE



High flexibility with all the required tools always available on board thanks to the **6-positions automatic tool changer**.



No scratches thanks to the new work table capable of processing lacquered and delicate panels.

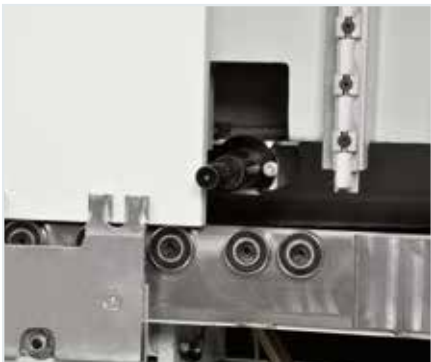

No repositioning and faster machining cycles thanks to the **dual shaped clamps**, to execute any type of drilling.



cx220

morbidelli cx210/cx220

CNC drilling centres



70% faster on drilling cycles thanks to 2 heads with independent Y and Z axes working simultaneously.



Not only drilling: dedicated unit for "Clamex" type connections.

Complete cycle with the dowel insertion device installed on the main Y carriage.

PRODUCTIVE, FLEXIBLE, VERSATILE

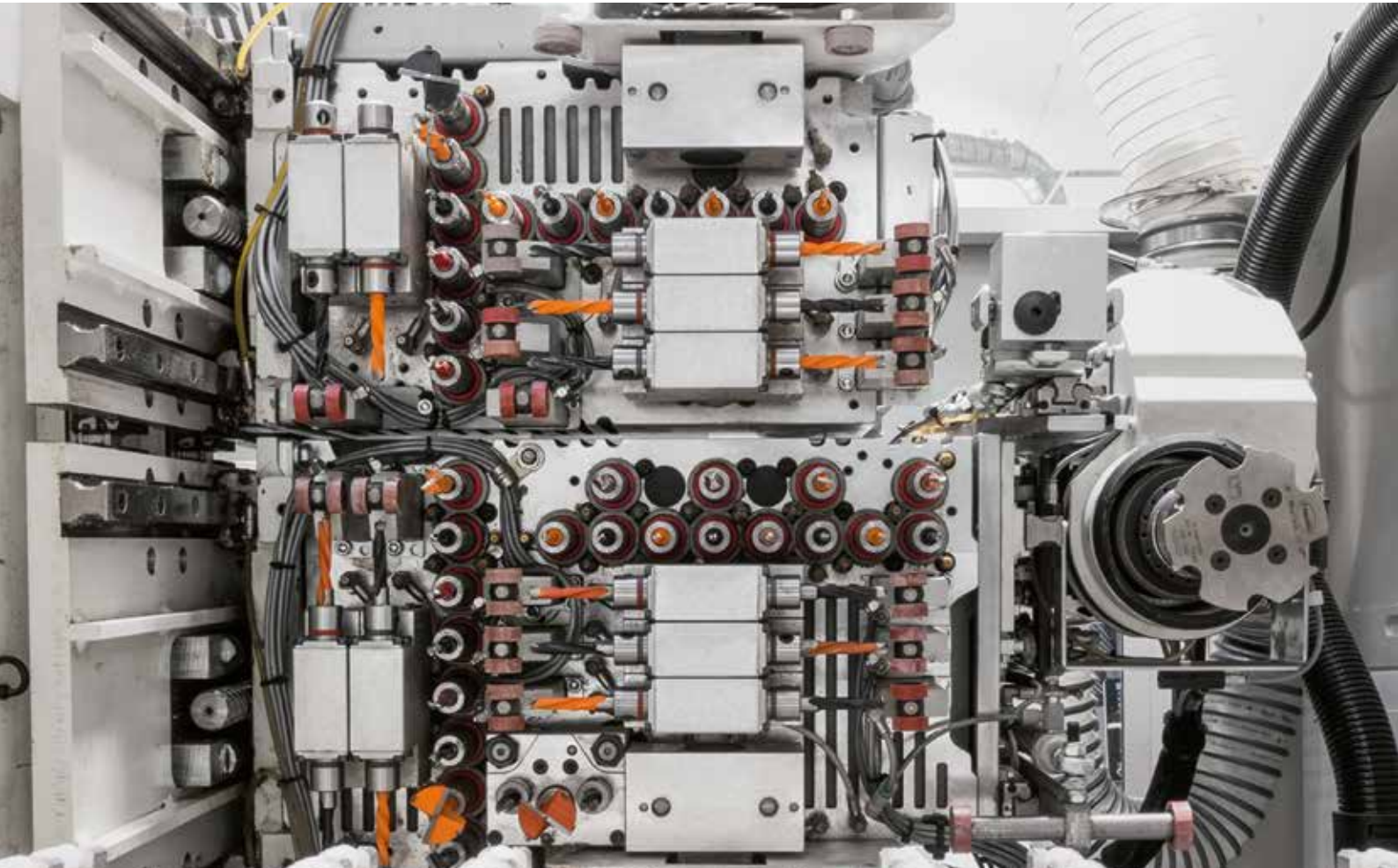

TAYLOR-MADE: CUSTOM DRILLING

The drilling unit has been specifically designed to have any tool always available on board to achieve all drilling operations in a few steps: 2 heads with Y and Z independent axes working simultaneously and enhancing the productivity.



QUALITY AT THE HEART: PERFECT DRILLING

Up to 55 RO.AX spindles (Rotoaxial spindle technology) on the double drilling head to execute all drilling operations without any need of manual intervention.

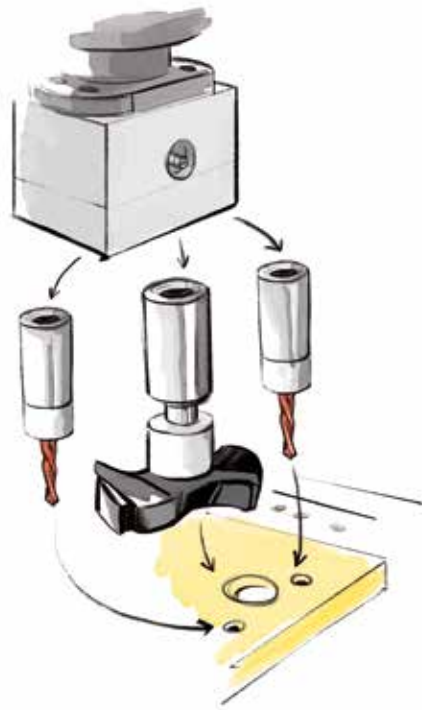

HINGE DRILLING: THE THREE IN ONE SOLUTION!

Possibility of carrying out 3 simultaneous drillings with a single head integrated in the main drilling unit.



PRODUCTIVE, FLEXIBLE, VERSATILE

INCOMPARABLE

OPERATING UNITS DESIGNED TO MEET ANY REQUIREMENT!



HIGHLY FUNCTIONAL AND RELIABLE

The 7.5 kW electrospindle with HSK63-F taper and rotation speed up to 24.000 rpm, is the ideal solution for local routing operations on various types of panels.

NOT ONLY DRILLS

Dedicated unit for "Clamex" type connections.

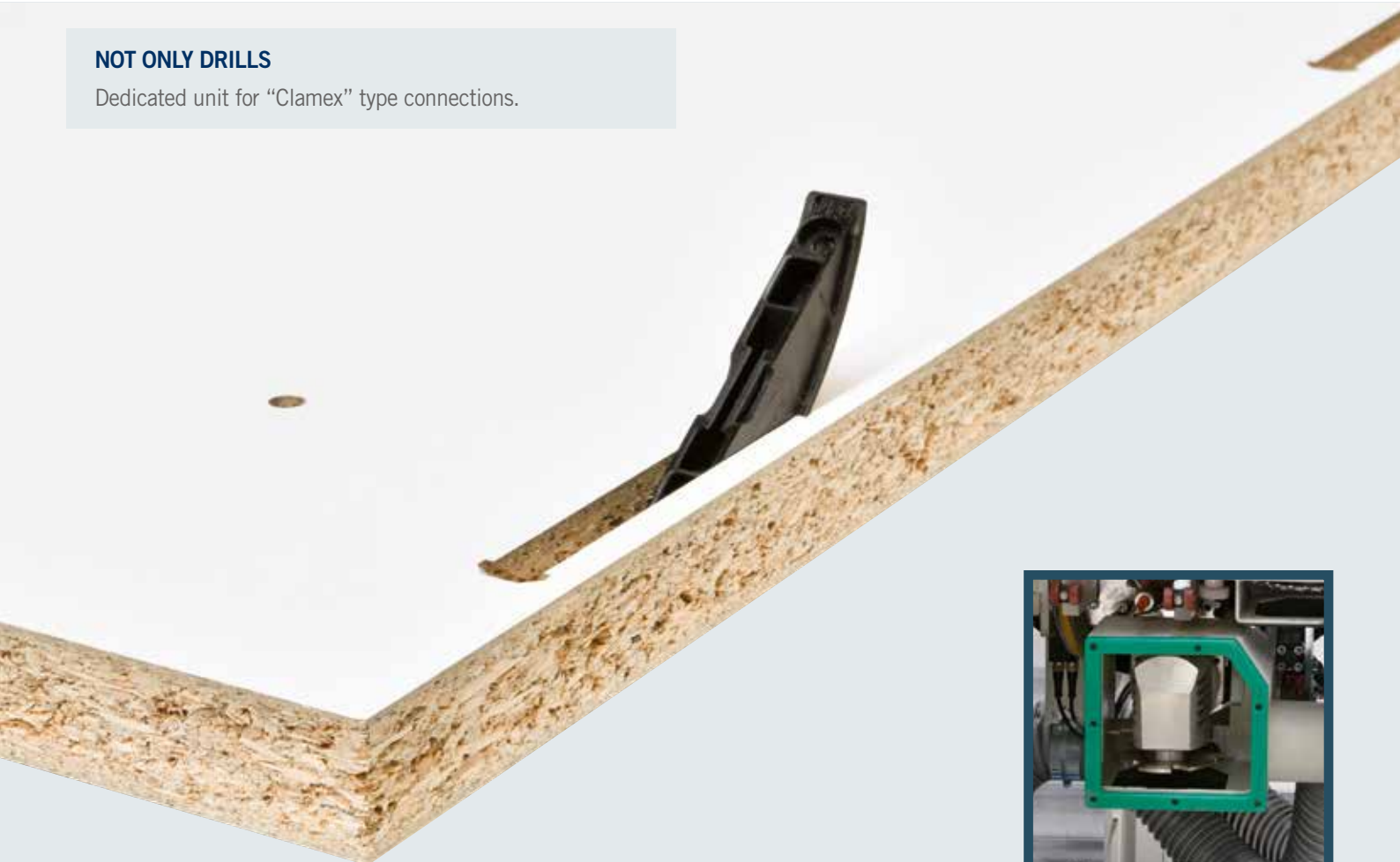



HIGH FLEXIBILITY

All the tools required for any furniture processing always available on board thanks to the **6-positions automatic tool changer**.

FULL WORK CYCLE

One or two **dowel insertion** devices installed on Y principal carriage and with independent Z-axis. Options available include the possibility of using the water system for pre-glued dowels or the vynilic glue dowels system.

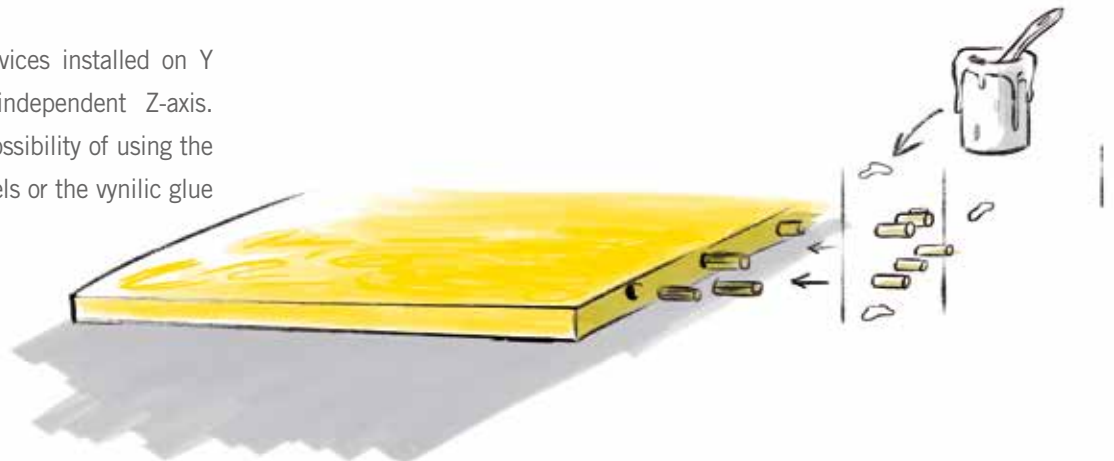

PRODUCTIVE, FLEXIBLE, VERSATILE



No scratches thanks to the new **work table** capable of processing lacquered and delicate panels.

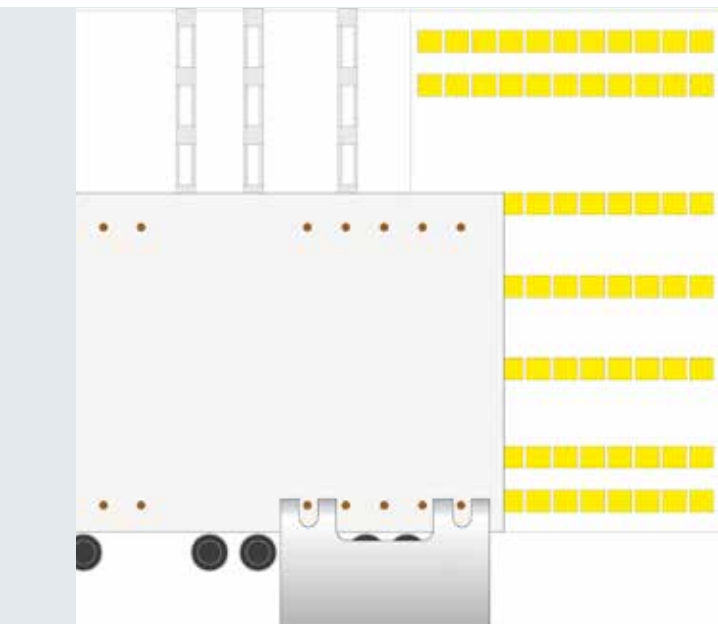

NO REPOSITIONING = MORE PRODUCTIVITY

Two shaped clamps to execute all required drilling operations without any need of repositioning.



NO MISTAKES THANKS TO “3D PROBE”,
the measuring device to detect panel's length,
width and thickness.



Quick and efficient panels loading thanks to the
adjustable mechanical reference stop.

PANEL LOADING-UNLOADING

MANUAL (cx100/cx110/cx210/CX220)

Manual loading and unloading with the possibility of unloading from both sides.



morbidelli range cx100/cx110/cx210/cx220

CNC drilling centres

WITH ROBOT (cx110/cx210/cx220)

Integration into the robot cell with the rear side of the machine, leaving the operator to load and unload from the front.

The possibilities are:

- automatic loading/unloading with robot
- automatic loading - manual unloading
- manual loading - automatic unloading



WITH PANEL RETURN CONVEYOR (cx110/cx210/cx220)

Panel return system consisting of a side conveyor and a return unit, for an ergonomic unloading position with workpiece storage function.



OVERALL DIMENSIONS

stand alone		A	B	C
morbidelli cx100	mm	4207	1915 / 3308	2154
morbidelli cx110	mm	4246	1995 / 3364	2123
morbidelli cx210/cx220	mm	4700	2241 / 3618	2850

STAND-ALONE

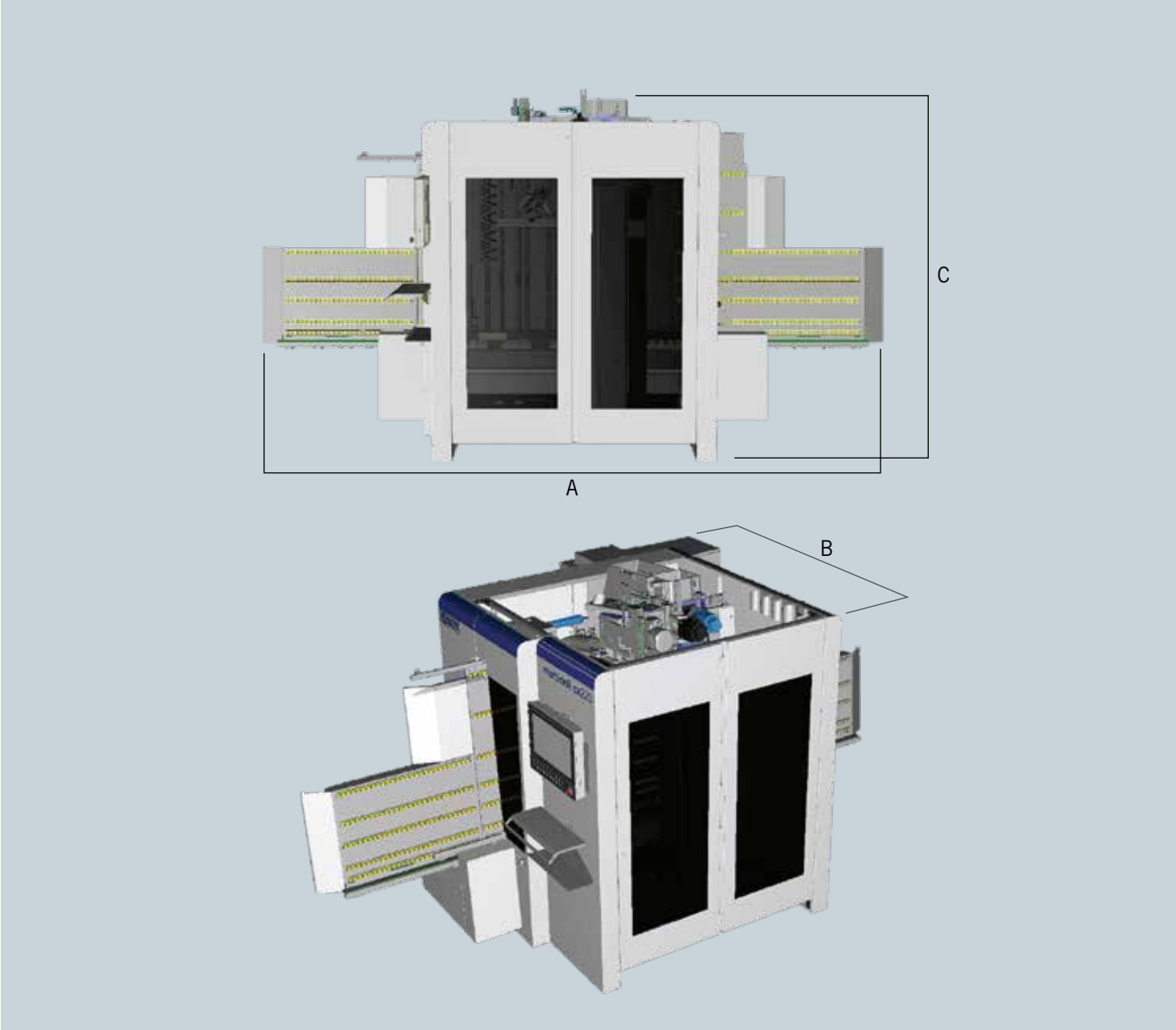

morbidelli range cx100/cx110/cx210/cx220

CNC drilling centres

with panel return conveyor		A	B	C
morbidelli cx110	mm	6680 / 6060	3800	2130
morbidelli cx210/cx220	mm	6700 / 7230	4070	2850

PANEL RETURN CONVEYOR

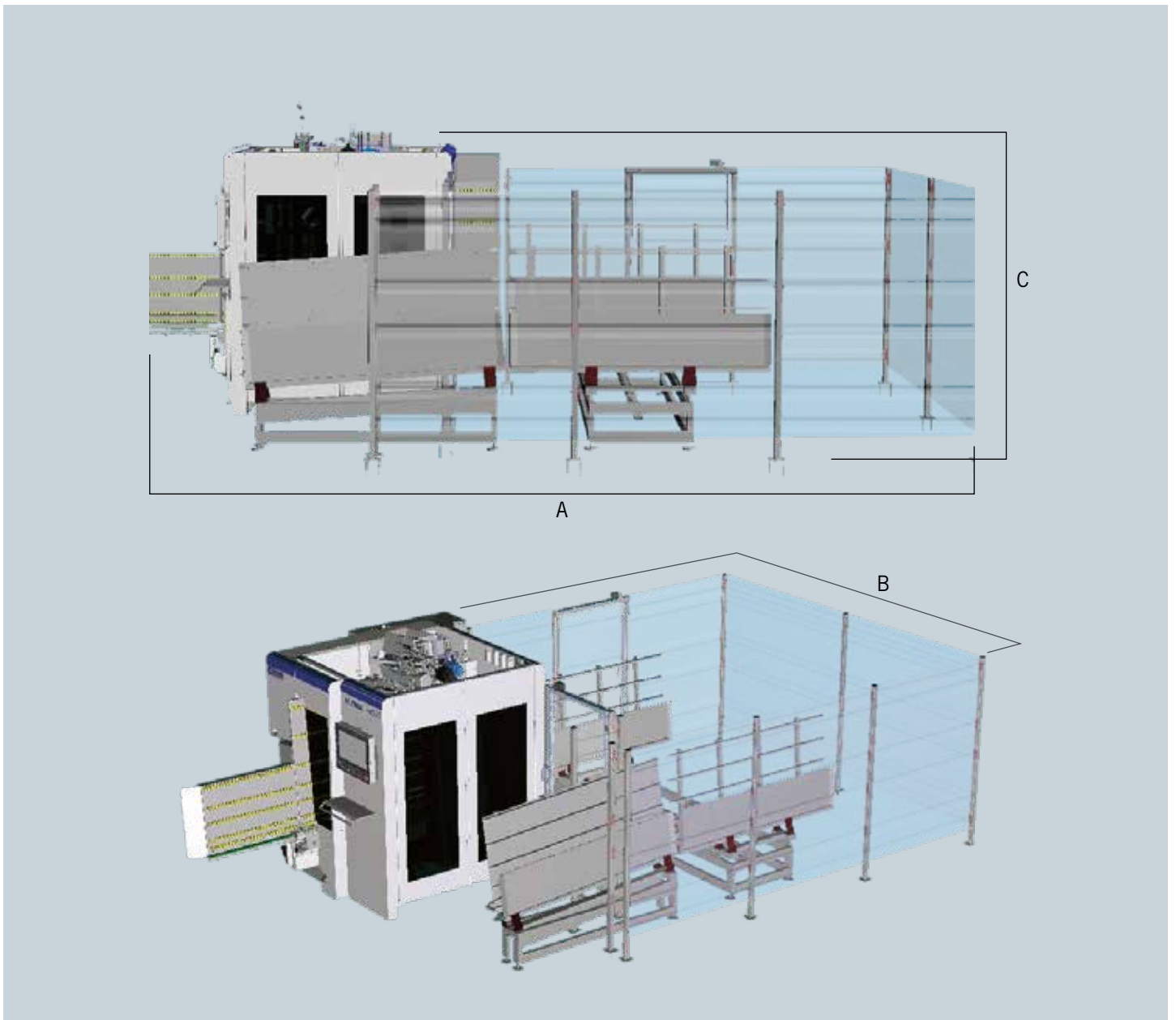

TECHNICAL DATA

morbidelli cx100

morbidelli cx100		
AXES		
Panel length min./max.	mm	200 / 3050
Panel width min./max.	mm	70 / 900
Panel thickness min./max.	mm	10 / 60
Panel weight max.	kg	30
Max. axes X-Y speed	m/min	40 - 40
F18L DRILLING HEAD		
Independent vertical spindles	no.	12 (7+5)
Independent horizontal spindles	no.	6 (4X+2Y)
Rotation speed	rpm	4200 (up to 3000 / 8000 with Inverter)
Integrated saw-blade in X	∅ rpm	125 5000 (up to 10.000 with Inverter)
ROUTING UNIT (opt.)		
ER32 electrospindle	kW (hp) rpm	5,5 (7,5) 1500 / 18.000
ISO30 electrospindle	kW (hp) rpm	4,5 (6) 1500 / 24.000

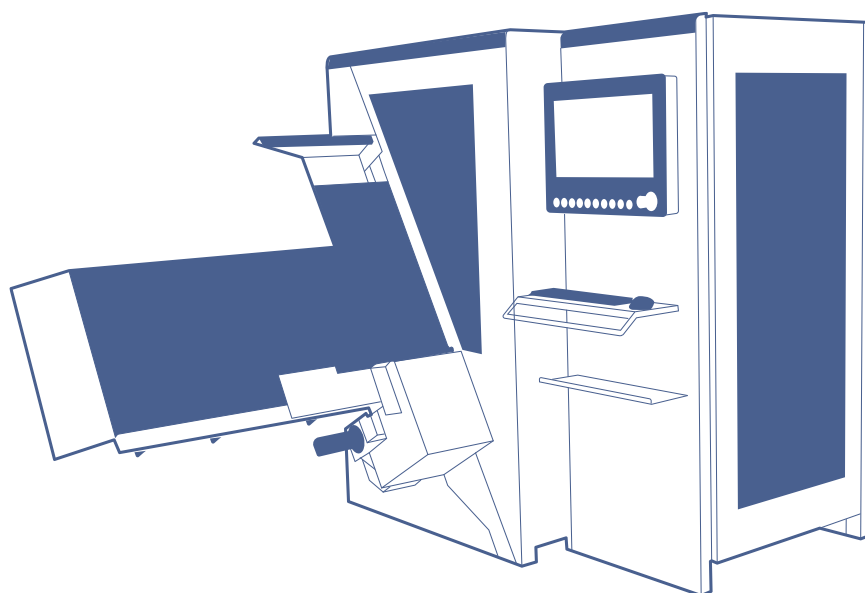

morbidelli cx110

morbidelli range cx100/cx110/cx210/cx220

CNC drilling centres

morbidelli cx110

AXES		
Panel length min./max.	mm	200 / 3050
Panel width min./max.	mm	50 / 950
Panel thickness min./max.	mm	8 / 60
Panel weight max.	kg	60
Max. axes X-Y-Z speed	m/min	50 - 40 - 30
3D PROBE copying system	/	std.

F19L DRILLING HEAD

Vertical spindles	no.	13
Horizontal spindles	no.	6 (4X+2Y)
Rotation speed	rpm	4200 (up to 3000 / 8000 with Inverter)
Integrated saw-blade in X	∅	125
	rpm	5000 (up to 10.000 with Inverter)

F23L DRILLING HEAD

Vertical spindles	no.	13
Horizontal spindles	no.	10 (6X+4Y)
Rotation speed	rpm	4200 (up to 3000 / 8000 with Inverter)
Integrated saw-blade in X	∅	125
	rpm	5000 (up to 10.000 with Inverter)

ROUTING UNIT (opt.)

ER32 electrospindle	kW (hp)	5,5 (7,5)
	rpm	1500 / 18.000
HSK63-F electrospindle	kW (hp)	7,5 (10,2)
	rpm	1500 / 24.000
Tool changer	/	HSK63-F 6 positions

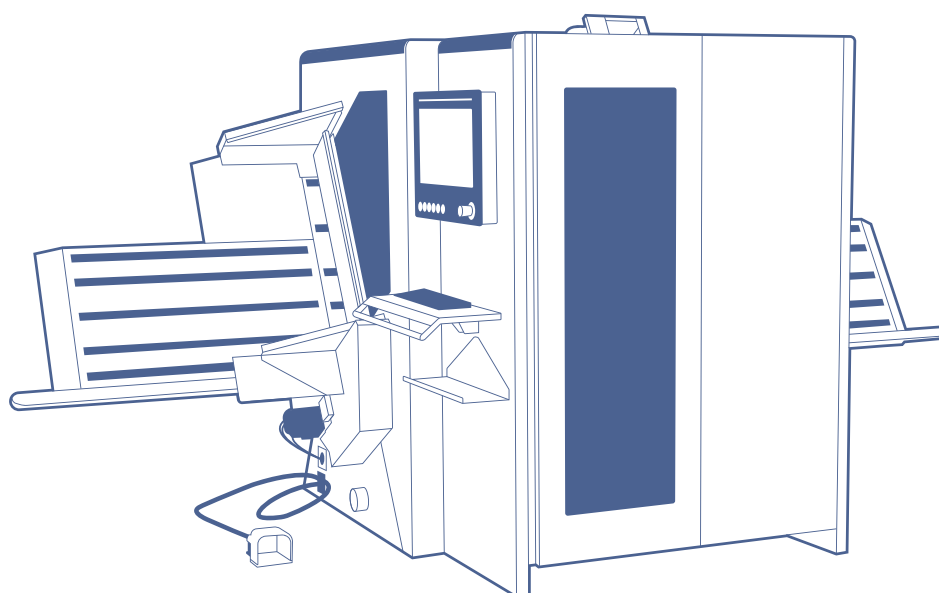

TECHNICAL DATA

morbidelli cx210/cx220

morbidelli		cx210	cx220
AXES			
Panel length min./max.	mm	200 / 3050	
Panel width min./max.	mm	50 / 1300	
Panel thickness min./max.	mm	8 / 95	
Panel weight max.	kg	70	
Max. axes X-Y-Z speed	m/min	70 - 40 - 30	
3D PROBE copying system	/	std.	
F31LTC DRILLING HEAD			
Vertical spindles	no.	21	
Horizontal spindles	no.	10 (6X+4Y)	
Rotation speed	rpm	4200 (up to 3000 / 8000 with Inverter)	
Integrated saw-blade in X	∅ rpm	125 5000 (up to 10.000 with Inverter)	
F21L DRILLING HEAD			
Vertical spindles	no.	/	13
Horizontal spindles	no.	/	8 (6X+2Y)
Rotation speed	rpm	/	4200 (up to 3000 / 8000 with Inverter)
Integrated saw-blade in X	∅ rpm	/	125 5000 (up to 10.000 with Inverter)
ROUTING UNIT (opt.)			
HSK63-F electrospindle	kW (hp) rpm	7,5 (10,2) 1500 / 24.0000	
Tool changer	positions	6	
OPTIONAL UNITS			
Saw-blade/Clamex	/	0° - 90°	
Dowel insertion devices	no.	1 right+1 left	2 right+2 left

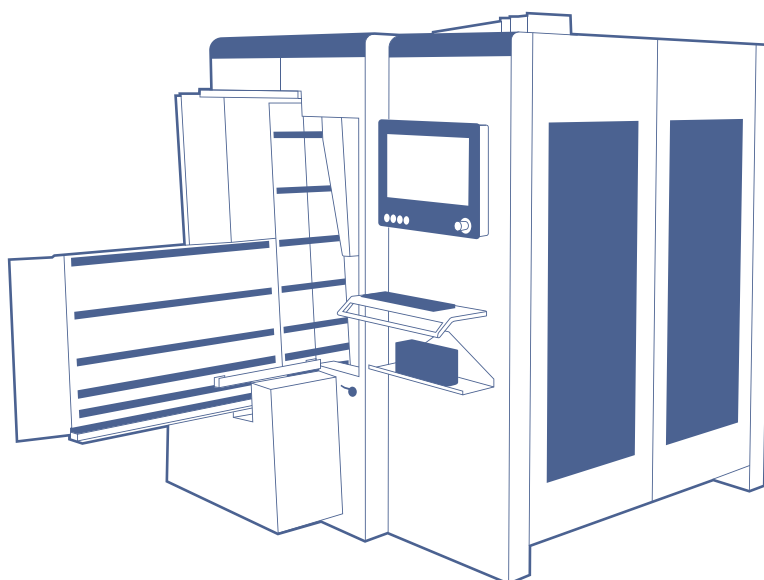



M Maestro Digital Systems

SMART SOFTWARE AND DIGITAL SERVICES TO ENHANCE PRODUCTIVITY OF WOODWORKING AND FURNITURE INDUSTRIES.

design > programming and data generation

Maestro office

Office

Factory

Maestro active

cutting > routing drilling edgebanding

SOFTWARE

Simple, smart and open Maestro software are tailored on the machine technology as well as on the entire process. All Maestro software share a common mission:

easy to use, so that any operator can easily and confidently learn and use the software

smart, with algorithms and computing modules aiming at the best possible result

open in order to integrate existing software, and provide customer the coverage of all his process.



SCM accompanies woodworking companies throughout their whole process combining machines with matching software solutions and digital services, with a constant strive to enhance company productivity.

The software solutions powered by SCM are developed to optimize machine usage as well as the entire process, providing integration with the different software existing in the company.

DIGITAL SERVICES

Transforming the way it delivers services to its customers through digital technologies and particularly, the IoT platform that collects and analyses data coming from the machine, **SCM created a world of services enabled by Maestro connect.**

Meaning that connecting an SCM machine through Maestro connect will let customer subscribe a program of fast-evolving services and access a wide range of benefits that even go beyond the machine experience and will support and assist you through the whole life-cycle of your machine.

Maestro connect IoT Platform

1
Machine monitoring,
KPIs, early warning

2
Maintenance
equipment

3
Predictive
maintenance

4
Report and historical
data export to MES

5
Warranty
extension

6
Augmented
remote support

7
Smart learning,
SELF-HEALING,
video tutorials

8
Asset management
with e-shop SCM
Spare Parts



SOFTWARE

Maestro lab

From the office, the Maestro lab design and programming system ensures that all machining can quickly and easily be programmed.

Transforming an idea into a finished product has never been easier.

More than 150 already integrated apps allow to generate cnc programs with just a few mouse clicks.



Office

THE SOFTWARE THAT SIMPLIFIES THE WORK

CAD/CAM programming software to design all the production processes. Developed in Windows environment it ensures easy programming with an advanced, simple and intuitive sketching environment that features all the tools necessary to design the parts, tools management and the relative machining operations.

All the procedures are contained in a perfectly integrated and high performance software.

SUITE



Maestro apps

Maestro apps is a library of programming functions that are always available and easy to use, developed by SCM for the production of parts for doors, windows, stairs, furniture and furnishings.



Maestro msl connector

Connettore con software di progettazione di terze parti.



Maestro 3Drill

Module for the automatic detection of holes and the application of machining on surfaces.



Maestro active cnc

Maestro active is the interface that the operator easily uses on all SCM machines: Maestro active interface software maintains the same look&feel, the same icons and the same approach to interaction.

EASE OF USE

The interface has been specifically designed and optimised for immediate use via touch screen, for a simple and comfortable navigation.

“ZERO” ERRORS

Improved productivity thanks to integrated help and recovery procedures that reduce the possibility of operator error.

Factory

A REVOLUTIONARY APPROACH TO INTERACT WITH YOUR SCM MACHINE

FULL CONTROL OF PRODUCTION PERFORMANCES

The creation of customisable reports by operator, shift, program, forecast period (and much more) allows to monitor, optimise and improve the performance.

FULL MACHINE AWARENESS AND KNOWLEDGE MANAGEMENT SYSTEM

Recording of maintenance, training and other events, tracing all the activities in a database. The operator's know-how is also stored and made available to other people inside the organisation thanks to the possibility to comment and document all production events or notifications.

ORGANIZE YOUR PRODUCTION

Creation of different users with different roles and authorisations (e.g.: operator, maintainer, administrator, ...). Possibility of defining the work shifts on the machine and then detect activities, productivity and events that occurred in each shift.

TOTAL QUALITY OF THE FINISHED PRODUCT

The quality of finished piece is no longer put at risk by worn tools. The new Maestro active Tool Life Determination system sends notification messages as the tool reaches its end of life and recommends its replacement at the most appropriate time.

TOOLS? NO PROBLEM!

Maestro active guides the operator during the tool change phase, taking into account the programs to be executed.

A WORLD OF SERVICES FOR GREATER EFFICIENCY

Maestro connect

CONNECT YOUR MACHINE AND GAIN ACCESS TO A WORLD OF SERVICES

Connecting your machine through Maestro connect will let you subscribe a program of fastevolving services. You will access a wide range of benefits that even go beyond the machine experience and will support and assist you through the whole life-cycle of your machine.

FASTER SERVICE INTERVENTION AND PROBLEM RESOLUTION

Maestro connect provides real time data and Health Records of the Machine also to SCM Service drastically reducing its troubleshooting time.

WORKING ALWAYS IN PERFECT CONDITIONS

Maestro Connect can provide a full kit of sophisticated sensor devices to detect and warn the operator in case of alarming conditions of the machine.

DIGITAL SERVICES

SMART MAINTENANCE: DOWN TIME REDUCTION

Maestro connect reduces maintenance downtime thanks to:

- Automatic maintenance notifications and scheduling, to prevent failures and work in the best conditions of use
- Direct connection to SCM Service thanks to an automatic ticket opening function

SMART MACHINE: ANYTIME, ANYWHERE AWARENESS

Connecting your SCM machine also means having your machine always at hand. Immediate instant notifications in case of alarms or downtimes allow customers to immediately take an action thus optimizing his productivity.

SMART MANAGEMENT: PRODUCTION PERFORMANCE OPTIMIZATION

Reports and KPIs allow further analysis thus increasing Customer Knowledge about his performance and results.

SMART PARTS: FAST PARTS REPLENISHMENT

Repairs are scheduled proactively since the system provides Spare Parts suggestions and a direct Integration with Smart Parts e-shop.

SMART LEARNING: EXECUTE WORK AND RECEIVE PROBLEM SOLVING SUPPORT

Maestro connect provides an intuitive Problem Solving Management System to help the operator to self solve any issue..

SMARTECH: FASTER AUGMENTED SUPPORT

Maestro connect allows augmented reality support by means of Smartech: the head-wearable computers with wireless connectivity that will bring the interaction between customer and SCM service to a higher level.

SMART WARRANTY: YOUR MACHINE ALWAYS IN PERFECT CONDITIONS

Together with scheduled maintenance contracts, you can take care of your asset by doubling the warranty from 1 year to 2 years* for complete peace of mind!

** please read the complete contract to understand terms and conditions.*

SAVENERGY

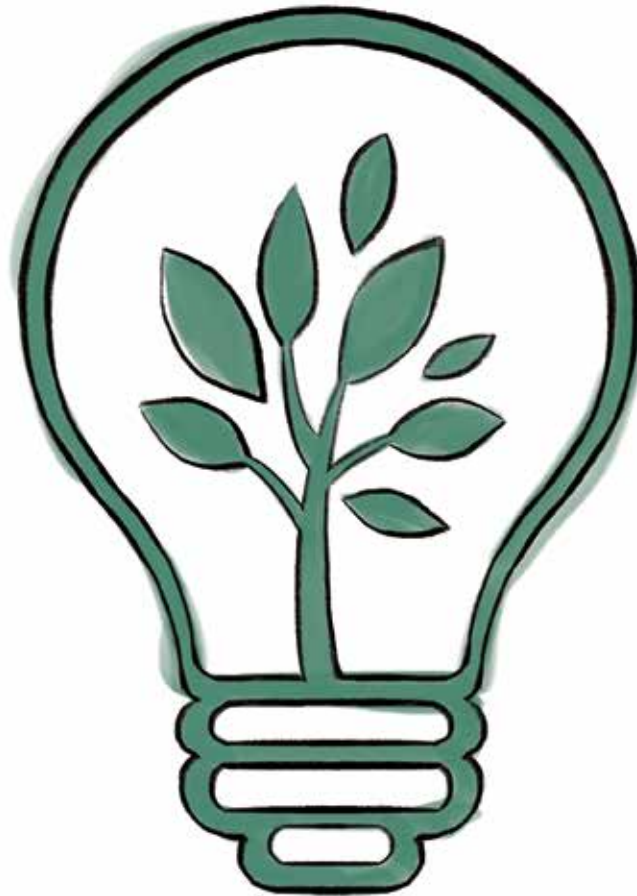

**COMPANY WITH
QUALITY SYSTEM
CERTIFIED BY DNV
ISO 9001**

THE USE OF POWER ONLY WHEN IT IS REQUIRED

SavEnergy allows making things operate only when they are really necessary. It means the machine automatically enters “stand-by” mode when there are no panels to be machined.

The technical data can vary according to the requested machine composition. In this catalogue, machines are shown with options. The company reserves the right to modify technical specifications without prior notice; the modifications do not influence the safety foreseen by the CE Norms.

Maximum noise levels measured according to the operating conditions established by EN 848-3:2012
Acoustic pressure in process (routing) 81 dbA (measured according to EN ISO 11202:2010, uncertainty K = 4 dB)
Acoustic power in process (routing) 98 dbA measured according to EN ISO 3746:2010, uncertainty K = 4 dB)





Even if there is a correlation between above mentioned “conventional” noise emission values and average levels of personal exposure over eight hours of operators, these last also depend on the real operating conditions, duration of exposure, acoustic conditions of the working environment and presence of further noise sources, this means the number of machines and other adjacent processes.

WE'LL GO THE EXTRA MILE FOR YOU



SCM OFFERS A FULL RANGE OF **HIGHLY SPECIALISED SERVICES** WITH A QUALITY AND RELIABILITY THAT STEM FROM 70 YEARS OF EXPERIENCE IN THE INDUSTRY.

From installation and production start-up to services and maintenance. From training to the supply of specific original spare parts: **we provide solutions designed around you!**

 <p>SERVICE AND MAINTENANCE</p> <ul style="list-style-type: none"> • Remote support • Scheduled maintenance contracts • Warranty extension 	 <p>TRAINING SERVICE</p> <ul style="list-style-type: none"> • Courses for machine operators • Software and programming courses • Training in production start-up
 <p>SPARE PARTS</p> <ul style="list-style-type: none"> • Recommended spare parts list • E-shop • Interactive spare-parts catalogues • Repairs on electronic parts, glue tanks and electro-spindles 	 <p>DIGITAL SERVICES</p> <ul style="list-style-type: none"> • Maestro Connect - IoT platform to be constantly connected with your machines • Smartech - assistance with augmented reality • My Scm portal - opening of service ticket and single point of access to the apps and Services tools

CONTACT

SCM SERVICE

via Emilia 77 - 47921 Rimini - Italy
tel. +39 0541 700100
scmservice@scmgroup.com
www.scmwood.com

SCM SPAREPARTS

Via Emilia, 61 - 47921 - Rimini - Italy
tel. +39 0541 674111
spareparts@scmgroup.com
www.scmwood.com



THE STRONGEST WOOD TECHNOLOGIES ARE IN OUR DNA

SCM. A HERITAGE OF SKILLS IN A UNIQUE BRAND

70 years of success gives SCM the centre stage in woodworking technology. This heritage results from bringing together the best know-how in machining and systems for wood-based manufacturing. SCM is present all over the world, brought to you by the widest distribution network in the industry.

70 years history

3 main production sites in Italy

300.000 square metres of production space

20.000 machines manufactured per year

90% export

20 foreign branches

400 agents and dealers

500 support technicians

500 registered patents



In SCM's DNA also strength and solidity of a great Group. The SCM Group is a world leader, manufacturing industrial equipment and components for machining the widest range of materials.

SCM GROUP, A HIGHLY SKILLED TEAM EXPERT IN INDUSTRIAL MACHINES AND COMPONENTS

INDUSTRIAL MACHINERY

Stand-alone machines, integrated systems and services dedicated to processing a wide range of materials.



WOODWORKING TECHNOLOGIES



TECHNOLOGIES FOR PROCESSING
COMPOSITE MATERIALS, ALUMINIUM,
PLASTIC, GLASS, STONE, METAL

INDUSTRIAL COMPONENTS

Technological components for the Group's machines and systems, for those of third-parties and the machinery industry.



SPINDLES AND
TECHNOLOGICAL
COMPONENTS



ELECTRIC PANELS



METALWORK



CAST IRON



SCM GROUP SPA
via Casale 450 - 47826 Villa Verucchio, Rimini - Italy
tel. +39 0541 674111 - scm@scmgroup.com
www.scmwood.com



00L0834840B