

minimax ad 21

manual drilling machine



All “Made in SCM Italy”

From casting iron to finished product.

Come see our production plants and touch the quality of SCM machines; you will be our guest.





minimax

the passion that deserves professional products.

minimax is the line of professional machines for woodworkers, a point of reference for over 40 years worldwide.

SCM's objective is to guarantee customers high quality technologies which meet their requirements in such a way as to make SCM the partner for any needs.

minimax ad 21

For all drilling requirements.

Single-head multi-drilling machine with 21 spindles.

Ideal solution for woodworking shops and demanding craftsmen.

drilling machine ad 21



		ad 21
Max. panel width under the bridge	mm	833
Worktable dimensions	mm	905 x 372
Worktable height	mm	900
Max. tool diameter	mm	40
Min.-max. panel height	mm	10 ÷ 85
Spindles speed rotation	rpm	2800
<i>Find the complete technical specification at page 7</i>		



Drilling Head
perfect drilling operation



Cleaning System
very high efficiency



Group for Hinges
high-tech devices

Single-head multi-drilling machine with 21 spindles. Ideal solution for woodworking shops and demanding craftsmen.

ad 21 machining units



A perfect vertical, horizontal and at 45° drilling operation.



perfect drilling

Drilling Head.

Drilling head made from single-piece aluminium casting, to guarantee absence of vibrations. The drilling unit runs on two rectified cylindrical guides which guarantee stability and precision. The machine is equipped with a mechanical revolver with 5 different drilling depth adjustments. The **new dust extraction system is incredibly efficient**, and leaves the machine surprisingly clean!

The mechanical gauge guarantees fast and precise positioning of the lateral fences.

Bits replaced quickly and easily!
The machine has 21 quick-change chucks.



All controls are ergonomically positioned on the front of the machine. This includes the switch which sets the drilling head at a 45° angle, allowing for an immediate changeover between operations. For perfect drilling of large panels, the machine has a long 3000 mm fence with a scale and retractable stops. The fence is quickly mounted and removed easily.

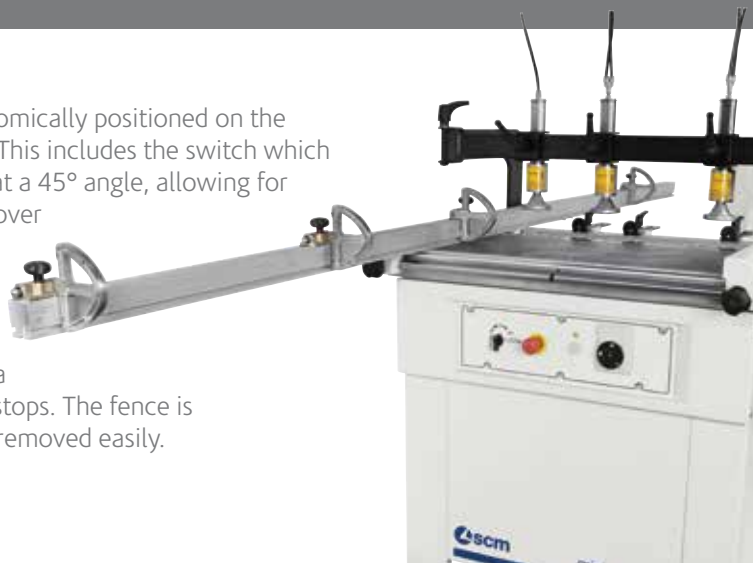

high-tech devices

Groups for Hinges.

For increased versatility, the quick-change chucks can be fitted with various types of bits for different operations, like drilling hinges locations.



ad 21 dimensions and technical data

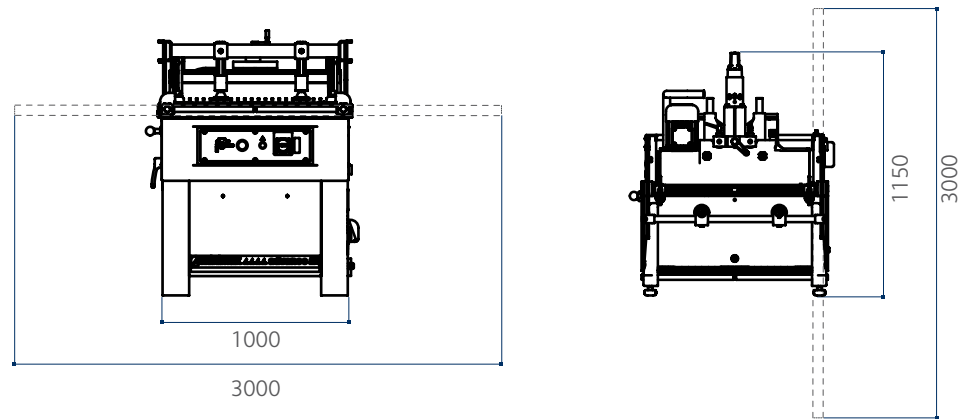

		ad 21
Worktable dimensions	mm	905 x 372
Worktable height	mm	900
Spindles number		21
Spindles centre-to-centre	mm	32
Maximum tool diameter	mm	40
Maximum drilling centre-to-centre	mm	640
Max. height of horizontal drilling operation	mm	60
Spindle speed	rpm	2800
Min./max. panel thickness	mm	10/85
Max. panel width under the bridge	mm	833
Max. drilling head stroke	mm	70
Drilling head motor power	kW	1,8
Pneumatic system operating pressure	bar	6
Air consumption	l/cycle	3,5
Exhaust outlets diameter	mm	80

WE'LL GO THE EXTRA MILE FOR YOU



SERVICE AND MAINTENANCE



TRAINING SERVICE



SPARE PARTS



DIGITAL SERVICES

SCM OFFERS A FULL RANGE OF **HIGHLY SPECIALISED SERVICES** WITH A QUALITY AND RELIABILITY THAT STEM FROM 70 YEARS OF EXPERIENCE IN THE INDUSTRY.

From installation and production start-up to services and maintenance. From training to the supply of specific original spare parts: **we provide solutions designed around you!**

CONTACT

SCM SERVICE
via Emilia 77 - 47921 Rimini - Italy
tel. +39 0541 700100
scmservice@scmgroup.com
www.scmwood.com

SCM SPAREPARTS
Via Emilia, 61 - 47921 - Rimini - Italy
tel. +39 0541 674111
spareparts@scmgroup.com
www.scmwood.com

My Scm



SERVICE AND MAINTENANCE

- Remote support
- Scheduled maintenance contracts
- Warranty extension



TRAINING SERVICE

- Courses for machine operators
- Software and programming courses
- Training in production start-up



SPARE PARTS

- Recommended spare parts list
- E-shop
- Interactive spare-parts catalogues
- Repairs on electronic parts, glue tanks and electro-spindles



DIGITAL SERVICES

- Maestro Connect - IoT platform to be constantly connected with your machines
- Smartech - assistance with augmented reality
- My Scm portal - opening of service ticket and single point of access to the apps and Services tools

THE STRONGEST WOOD TECHNOLOGIES ARE IN OUR DNA

SCM. A HERITAGE OF SKILLS IN A UNIQUE BRAND

70 years of success gives SCM the centre stage in woodworking technology. This heritage results from bringing together the best know-how in machining and systems for wood-based manufacturing. SCM is present all over the world, brought to you by the widest distribution network in the industry.

70 years history

3 main production sites in Italy

300.000 square metres of production space

20.000 machines manufactured per year

90% export

20 foreign branches

400 agents and dealers

500 support technicians

500 registered patents

In SCM's DNA also strength and solidity of a great Group. The SCM Group is a world leader, manufacturing industrial equipment and components for machining the widest range of materials.

SCM GROUP, A HIGHLY SKILLED TEAM EXPERT IN INDUSTRIAL MACHINES AND COMPONENTS

INDUSTRIAL MACHINERY

Stand-alone machines, integrated systems and services dedicated to processing a wide range of materials.



WOODWORKING TECHNOLOGIES



TECHNOLOGIES FOR PROCESSING
COMPOSITE MATERIALS, ALUMINIUM,
PLASTIC, GLASS, STONE, METAL

INDUSTRIAL COMPONENTS

Technological components for the Group's machines and systems, for those of third-parties and the machinery industry.



SPINDLES AND
TECHNOLOGICAL
COMPONENTS



ELECTRIC PANELS



METALWORK



CAST IRON



is more



Company of the Scm Group

registered office:

via Emilia, 77
47921 Rimini, Italia
T. +39 0541 700111
F. +39 0541 700232

sales office:

via Casale, 450
47826 Villa Verucchio, Rimini, Italia
T. +39 0541 674111
F. +39 0541 674274
scm@scmgroup.com
www.scmwood.com

Scm Industria Spa

Professional Workshop Machinery

via Valdicella, 7
47892 Gualdicciolo,
Repubblica di San Marino
scm@scmgroup.com

sales dept. Italy:

T. +378 0549 876911
F. +378 0549 999604

foreign sales dept.:

T. +39 0541 674111
F. +39 0541 674274
www.scmwood.com

The motors powers in this catalogue are expressed in S6, except where otherwise specified. In this catalogue, machines are shown in CE configuration and with options. We reserve the right to modify technical specifications without prior notice, provided that such modifications do not affect safety as per CE norms.

rev.01
10/2024

Mic Studio





SCM GROUP SPA

via Casale 450 - 47826 Villa Verucchio, Rimini - Italy
tel. +39 0541 674111 - fax +39 0541 674274
scm@scmgroup.com
www.scmwood.com