

# minimax *line*

genius range



# All “Made in SCM Italy”

*From casting iron to finished product.*

Come see our production plants and touch the quality of SCM machines;  
you will be our guest.



## minimax

the passion that deserves professional products.

minimax is the line of professional machines for woodworkers, a point of reference for over 40 years worldwide.

SCM's objective is to guarantee customers high quality technologies which meet their requirements in such a way as to make SCM the partner for any needs.

## genius

All the minimax quality at the more accessible price.

universal combined  
machines

**c 30g**  
page 6



**c 26g**  
page 7



combined machines

**fs 30g**  
page 8



**st 1g**  
page 8



circular saw

**sc 1g**  
page 9





# App Thundercut

Technology at your fingertips

SCM Thundercut is the Optimizer/Sequencer App for mobile devices, that allows to optimize the panel surface and guides the operator through the cutting sequence.

**High cut speed execution, less material waste and mistake odds minimized, even for not skilled workers!**

Download it now from the AppStore and Google Play:

SCM Thundercut



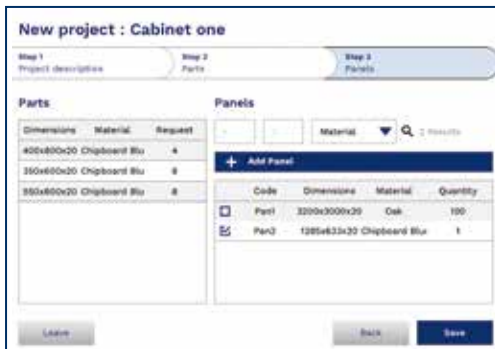
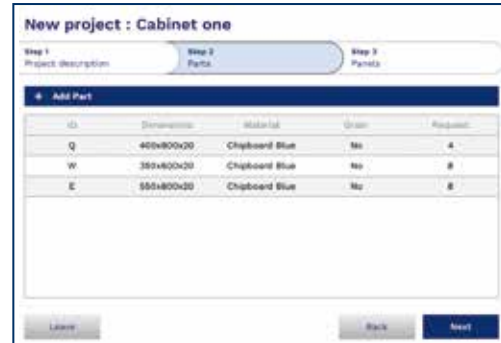
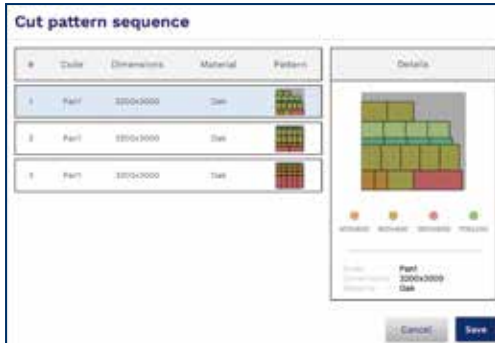

You can manage your circular saws fleet, the material warehouse and many project you are working on.



The 3D sequencer, thanks to its simple and clear design, suggest the ideal settings of the machine for every single cut to be executed.

The App is available for circular saws, circular saws with movable blade unit, saw-shaper combination machines and universal combination machines (you will find the QR code to activate the App in each new machine).

genius  
universal  
combined machines  
c 30g  
c 26g



		c 30g	c 26g
Planer useful working width	mm	300	260
Total length of surfacing tables	mm	1200	1040
Max. saw blade diameter	mm	250	250
Squaring stroke	mm	1200	1200
Max. spindle length	mm	75	75
Three-phase motors starting from	kW/Hz	1,8 (2,2) / 50 (60)	1,8 (2,2) / 50 (60)

Find the complete technical specification at page 12



**Saw Unit**  
cutting precision



**Surfacing Planer**  
fully equipped



**Thickening Planer**  
practical and ergonomic



**Spindle Moulder**  
flexibility



**Mortiser**  
functional



**SCM**  
**Thundercut**  
Optimizer/  
Sequencer App

genius  
combined machines  
circular saw  
fs 30g  
st 1g  
sc 1g

surfacing-thicknessing planer  
saw-spindle moulder  
circular saw



		fs 30g	st 1g	sc 1g
Planer useful working width	mm	300	-	-
Total length of surfacing tables	mm	1200	-	-
Max. saw blade diameter	mm	-	250	250
Squaring stroke	mm	-	1200	1200
Max. spindle length	mm	-	75	-
Three-phase motors starting from	kW/Hz	1,8 (2,2) / 50 (60)	1,8 (2,2) / 50 (60)	1,8 (2,2) / 50 (60)

Find the complete technical specification at page 12





**Saw Unit**  
cutting precision



**Surfacing Planer**  
fully equipped



**Thickening Planer**  
practical and ergonomic



**Spindle Moulder**  
flexibility



**Mortiser**  
functional



**SCM**  
**Thundercut**  
Optimizer/  
Sequencer App

# genius machining units



cutting precision

## Saw Unit.

Tilting saw unit with a 250 mm blade and a maximum blade projection from table at 90° of 80 mm. The saw unit can be raised and tilted using convenient hand-wheels. The anodized aluminum sliding table, with a 1200 mm stroke, slides **next to the blade**, thus ensuring better cutting precision.

practical and ergonomic

## Thickening Planing.

To keep the machine compact and make machining easier, the surfacing table opens towards the inside of the machine. Thanks to an efficient feed system, the thickening unit can process wood up to 200 mm thick.



functional and customisable

A machine even more versatile: with the practical **mortiser** (option) drilling holes or mortises are easily done.





safety first  
Genius machines have many **safety devices according to CE norms**, as like as the spindle moulder guard for curved profiles and moulding shapes.



fully equipped  
**Surfacing Planing.**

The planer unit has a cutter block with 2 re-usable knives (the "Tersa" disposable knives system with 3 knives and rapid clamping is available as an option). Genius machines also have saw-planer fences with an anodized aluminum extrusion and a support with clamp for fast positioning.



flexibility

**Spindle Moulder.**

Maximum flexibility in spindle moulder tool use, with the unit with 2 speed (5000/7500 rpm). The machines have a spindle moulder fence with micrometric adjustment, a feature which is particularly useful on profiling jobs. Tenoning is easy too, thanks to the aluminum sliding table, the right speed setting and the special protection hood (option).

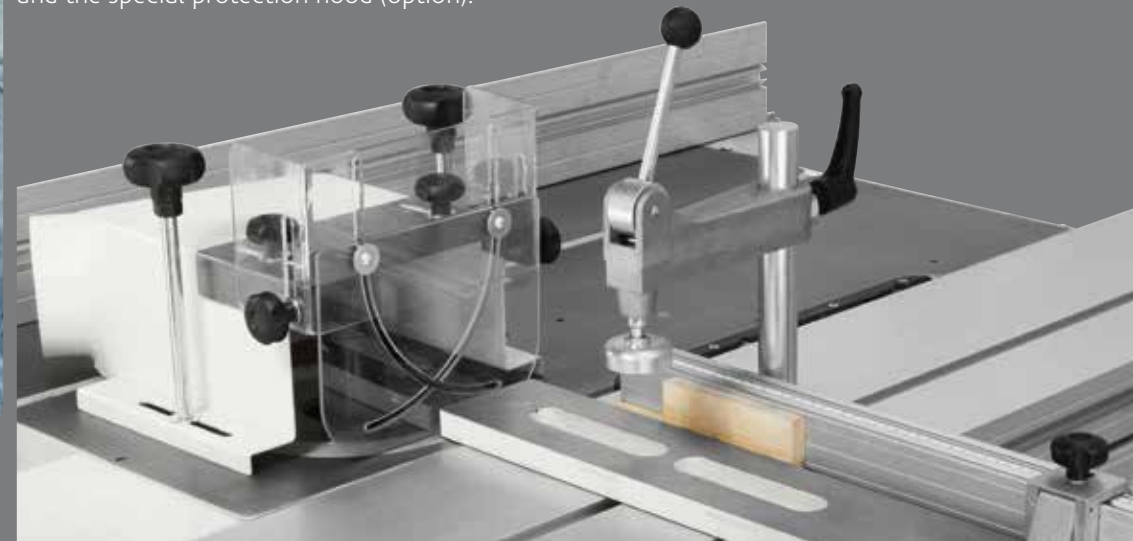

# genius dimensions and technical data

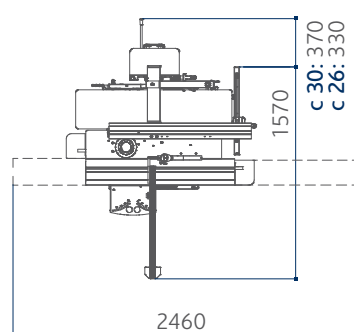

c 30g  
c 26g

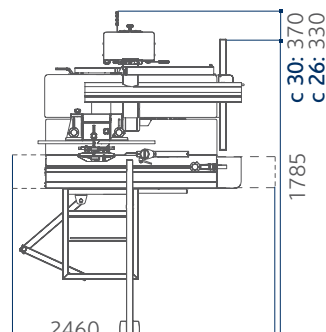

c 30g  
c 26g with support frame

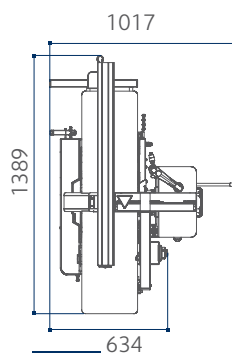

fs 30g

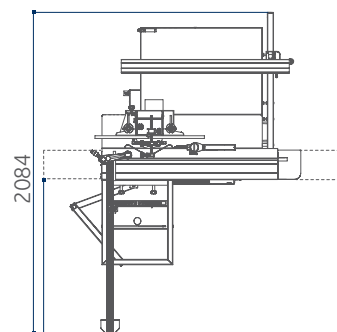

st 1g

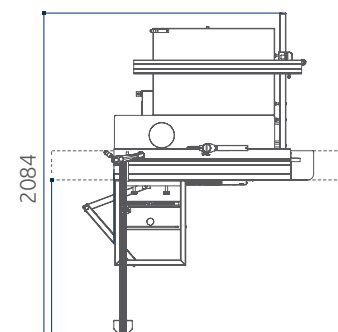

sc 1g

S Standard  
O Option

		c 30g	c 26g	fs 30g	st 1g	sc 1g
<b>planer</b>						
Working width	mm	300	260	300	-	-
Cutter block diameter (mm)/no. of standard knives	mm/n.	62 / 2	62 / 2	62 / 2	-	-
Dimensions of standard knives	mm	300 x 25 x 3	260 x 25 x 3	300 x 25 x 3	-	-
Max. stock removal	mm	3	3	3	-	-
Surfacing tables total length	mm	1200	1040	1200	-	-
Thickening table dimensions	mm	300 x 450	260 x 450	300 x 450	-	-
Feed speed on thickener	m/min	6	6	6	-	-
Min. ÷ max. working height on thickener	mm	3 ÷ 200	3 ÷ 200	3 ÷ 200	-	-
<b>circular saw</b>						
Cast iron saw-spindle moulder worktable dimensions	mm	1024 x 224	1024 x 224	-	1024 x 224	1024 x 224
Saw blade tilting		90° ÷ 45°	90° ÷ 45°	-	90° ÷ 45°	90° ÷ 45°
Max. saw blade diameter with scoring blade installed	mm	250	250	-	250	250
Max. saw blade projection from table at 90°/45°	mm	80 / 64	80 / 64	-	80 / 64	80 / 64
Squaring stroke	mm	1200	1200	-	1200	1200
Cutting width on parallel fence	mm	540	500	-	700	700
<b>spindle moulder</b>						
Max. useful spindle length	mm	75	75	-	75	-
Spindle moulder speeds (at 50 Hz)	rpm	5000 / 7500	5000 / 7500	-	5000 / 7500	-
Max. tool diameter when profiling	mm	160	160	-	160	-
Max. diameter of tool lowered under the table at 90°	mm	145	145	-	145	-
Max. tool diameter when tenoning	mm	200	200	-	200	-
<b>other technical features</b>						
Three-phase motors 1,8 kW (2,5 hp) 50 Hz – 2,2 kW (3 hp) 60 Hz		S	S	S	S	S
Three-phase motors 2,2 kW (3 hp) 50 Hz – 2,6 kW (3,6 hp) 60 Hz		O	O	O	O	O
Single-phase motors 1,8 kW (2,5 hp) 50 Hz		O	O	O	O	O
Single-phase motors S1 1,8 kW (2,5 hp) 60 Hz		O	O	O	O	O
Exhaust outlets diameter	mm	120	120	120	120	120



# genius main optional devices

tablet holder  
on the sliding  
carriage  
Compatible with  
tablets from  
8" to 11".



"minimax ease"  
mobile trolley  
for accessories  
Designed to store various  
accessories such as:  
surfacing fence, squaring  
fence, spindle moulder  
fence, spindle shafts, etc.



"Tersa" cutter block  
Automatic knives clamping by  
means of the centrifugal force  
ensures safe and precise machining.  
The system, without fixing screws,  
makes knives substitution  
extremely fast.



self-centering chuck  
0-16 mm "Wescott" type  
The mortiser spindles can be rapidly  
substituted without the necessity  
of adjustment.



tenoning table and  
protection hood  
For the tenoning operations on the spindle  
moulder. It consists of:  
- table  
- protection hood for tools,  
200 mm diameter  
- exhaust hood, 120 mm diameter



maintenance case for  
"Xylent" spiralknife

Complete with:

- 1 cleaning/degreasing liquid bottle  
for the resins cleaning
- 1 set dynamometric key
- 2 bit Torx
- 10 inserts
- 5 screws
- 1 brass bristle brush to clean the spindle with mounted in inserts
- 1 steel bristle brush to clean the inserts housings



"Xylent" spiralknife cutter block  
with 3 series of knives

The 3 spiralknives give an exceptional finish.  
Reduced noise during machining provides  
a more comfortable working environment.  
It also improves the dust extraction due to  
the production of very small chips. Each  
cutter has 4 tips which can be rotated into  
the cutting position when worn. Therefore  
increasing the production life of the cutter  
block before knives require replacement.



# genius main optional devices

S Standard  
O Option

	c 30g	c 26g	fs 30g	st 1g	sc 1g
"SCM Thundercut" Optimizer/Sequencer App	S	S	-	S	S
Tablet holder on the sliding carriage	O	O	-	O	O
"Tersa" cutter block	O	O	O	-	-
"Xylent" spiralknife cutter block with 3 series of knives	O	O	O	-	-
Maintenance case for "Xylent" spiralknife	O	O	O	-	-
Self-centering chuck 0-16 mm "Wescott" type	O	O	O	-	-
Tenoning table and protection hood	O	O	-	O	-

# WE'LL GO THE EXTRA MILE FOR YOU



SERVICE AND MAINTENANCE



TRAINING SERVICE



SPARE PARTS



DIGITAL SERVICES

SCM OFFERS A FULL RANGE OF **HIGHLY SPECIALISED SERVICES** WITH A QUALITY AND RELIABILITY THAT STEM FROM 70 YEARS OF EXPERIENCE IN THE INDUSTRY.

From installation and production start-up to services and maintenance. From training to the supply of specific original spare parts: **we provide solutions designed around you!**

CONTACT

**SCM SERVICE**  
via Emilia 77 - 47921 Rimini - Italy  
tel. +39 0541 700100  
scmservice@scmgroup.com  
www.scmwood.com

**SCM SPAREPARTS**  
Via Emilia, 61 - 47921 - Rimini - Italy  
tel. +39 0541 674111  
spareparts@scmgroup.com  
www.scmwood.com

My Scm



SERVICE AND MAINTENANCE

- Remote support
- Scheduled maintenance contracts
- Warranty extension



TRAINING SERVICE

- Courses for machine operators
- Software and programming courses
- Training in production start-up



SPARE PARTS

- Recommended spare parts list
- E-shop
- Interactive spare-parts catalogues
- Repairs on electronic parts, glue tanks and electro-spindles



DIGITAL SERVICES

- Maestro Connect - IoT platform to be constantly connected with your machines
- Smartech - assistance with augmented reality
- My Scm portal - opening of service ticket and single point of access to the apps and Services tools



# THE STRONGEST WOOD TECHNOLOGIES ARE IN OUR DNA

## SCM. A HERITAGE OF SKILLS IN A UNIQUE BRAND

70 years of success gives SCM the centre stage in woodworking technology. This heritage results from bringing together the best know-how in machining and systems for wood-based manufacturing. SCM is present all over the world, brought to you by the widest distribution network in the industry.

**70** years history

**3** main production sites in Italy

**300.000** square metres of production space

**20.000** machines manufactured per year

**90%** export

**20** foreign branches

**400** agents and dealers

**500** support technicians

**500** registered patents

In SCM's DNA also strength and solidity of a great Group. The SCM Group is a world leader, manufacturing industrial equipment and components for machining the widest range of materials.

## SCM GROUP, A HIGHLY SKILLED TEAM EXPERT IN INDUSTRIAL MACHINES AND COMPONENTS

### INDUSTRIAL MACHINERY

Stand-alone machines, integrated systems and services dedicated to processing a wide range of materials.



WOODWORKING TECHNOLOGIES



TECHNOLOGIES FOR PROCESSING  
COMPOSITE MATERIALS, ALUMINIUM,  
PLASTIC, GLASS, STONE, METAL

### INDUSTRIAL COMPONENTS

Technological components for the Group's machines and systems, for those of third-parties and the machinery industry.



SPINDLES AND  
TECHNOLOGICAL  
COMPONENTS



ELECTRIC PANELS



METALWORK



CAST IRON



is more



**Company of the Scm Group**

**registered office:**

via Emilia, 77  
47921 Rimini, Italia  
T. +39 0541 700111  
F. +39 0541 700232

**sales office:**

via Casale, 450  
47826 Villa Verucchio, Rimini, Italia  
T. +39 0541 674111  
F. +39 0541 674274  
scm@scmgroup.com  
www.scmwood.com

**Scm Industria Spa**

**Professional Workshop Machinery**

via Valdicella, 7  
47892 Gualdicciolo,  
Repubblica di San Marino  
scm@scmgroup.com

**sales dept. Italy:**

T. +378 0549 876911  
F. +378 0549 999604

**foreign sales dept.:**

T. +39 0541 674111  
F. +39 0541 674274  
www.scmwood.com

The motors powers in this catalogue are expressed in S6, except where otherwise specified. In this catalogue, machines are shown in CE configuration and with options. We reserve the right to modify technical specifications without prior notice, provided that such modifications do not affect safety as per CE norms.

rev.02  
10/2024

Mic Studio





**SCM GROUP SPA**

via Casale 450 - 47826 Villa Verucchio, Rimini - Italy  
tel. +39 0541 674111 - fax +39 0541 674274  
scm@scmgroup.com  
www.scmwood.com



00L0593186C