

morbidelli m100/m200

numerical controlled machining centres



THE AFFORDABLE ALL-IN-ONE TECHNOLOGY

UNDERSTAND THE NEEDS TO BE...



... ALL RESPONSIVE



**EVERYTHING
YOU ALWAYS
DREAMED OF A
CNC MACHINING
CENTRE BUT
WERE TOO
AFRAID TO ASK**

4

MORBIDELLI M100/M200

FREEDOM

6

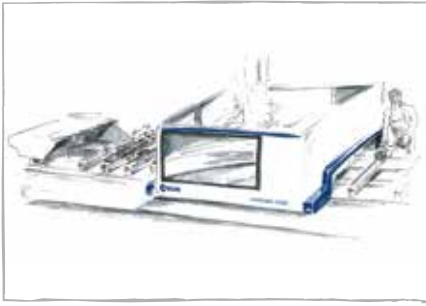

Optimizing the space in your factory thanks to the PRO-SPACE solution.

Accessible and ergonomic 360° all around, no floor obstructions: all the components are within the base.

Total safety and freedom to load large panels (as wide as 2200 mm) due to the work table being entirely accessible.

TOP QUALITY

12

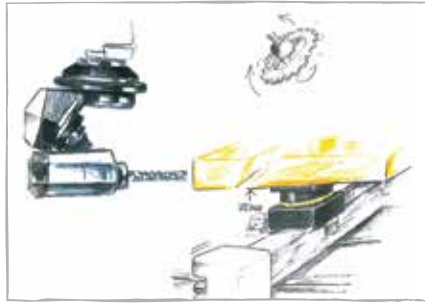

Unique to the market: up to 4 types of units to fit different working groups.

Unrivalled finishing with new direct drive JQX (Just Quality eXtreme) 5-axis electrospindle.

Reduced maintenance, thanks to the RO.AX (Rotoaxial spindle technology) drilling bits. It is recommended only after more than 1000 hours of work.

60% of time saved on drilling cycles with the new drill-bits designed to guarantee the best effectiveness on all types of material.

FASTER

24

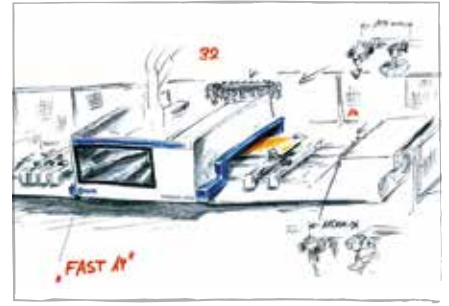

Beyond imagination, up to 60 tools always available on board make the machine the best in its class.

Less than 15" for the tool change with the 14 position FAST tool changer.

ALL

FLEXIBLE

28

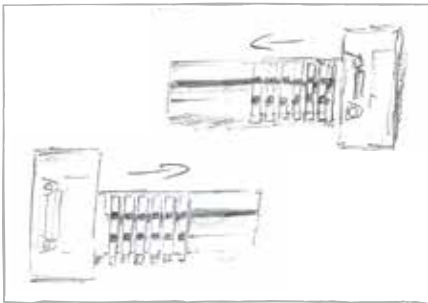

The machine is perfect for all types of materials: from wood to plastic, from panel to furniture, from kitchen doors to windows.

The right solution configured for all your needs and your investment plan.

Zero idle times for set-up operations and no compromise for the machine performance with the **versatility** and free **configurability** of the **TV FLEXMATIC** work table.

No limit for the work piece machining with thickness up to 180 or 250 mm on 75 mm vacuum pods.

CLEAN

38

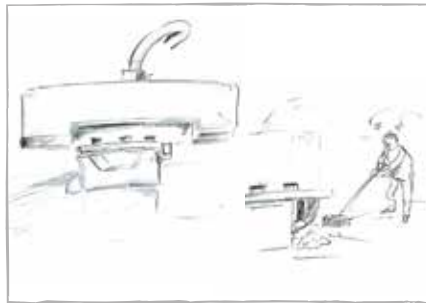

No problem with dust or shavings thanks to the intelligent solution of the dust collection box located in an ergonomic position.

Free space on the floor with the vacuum pump integrated in the machine base.

READY

42



1 technician, 1 day and the machine is up and running!

44

MAESTRO software

46

Technical data

100 REASONS TO BUY, 200 REASONS

EXCLUSIVE FEATURES

9



All at your fingertips thanks to the TECPAD 7" colour remote control with touch-screen.

10

Free access, having the cable-holder chain enclosed within the machine frame.

11



Rapid working cycles with the 14 position FAST tool changer.

8

Intuitiveness and easiness with the APPS included in the Maestro software for the production of doors, stairs, furniture and furnishing elements.

7

Integrated electrical cabinet with air conditioner.

6¹

*Zero idle times for set-up operations and no compromise for the machine performance with the **versatility** and free **configurability** of the TV FLEXMATIC work table.*

TO ENJOY

morbidelli m100/m200

numerical controlled machining centres

12



Wide availability of tools thanks to the **TRC** rear chain tool changer with 32 positions.

1



- **Total flexibility** with an operating group configurability unique to the market.
- **Unrivalled finishing** with new direct drive **JQX** (Just Quality eXtreme) 5-axis electrospindle.
- **60% of time saved** on drilling cycles with the new drill-bits designed to guarantee the best effectiveness on all types of material.
- **Reduced maintenance**, thanks to the **RO.AX** (Rotoaxial spindle technology) drilling bits. It is recommended only after more than 1000 hours of work.

2



TRB tool changer with 14 positions.

3



Free space on the floor with the vacuum pump integrated in the machine base.

5

100% of the working area covered by all the units of the operating group.

6²



Very high flexibility with the multi-function work table made of extruded aluminium, **extremely stiff**, designed to maintain a **perfect planarity over time**, even after repeated mechanical stresses; it is ideal also for nesting machining.

4



No problem with dust or shavings thanks to the intelligent solution of the dust collection box located in an ergonomic position.



EVERYTHING YOU ALWAYS DREAMED OF A CNC MACHINING CENTRE BUT WERE TOO AFRAID TO ASK

FREEDOM OF MOVEMENT



ALL FREEDOM

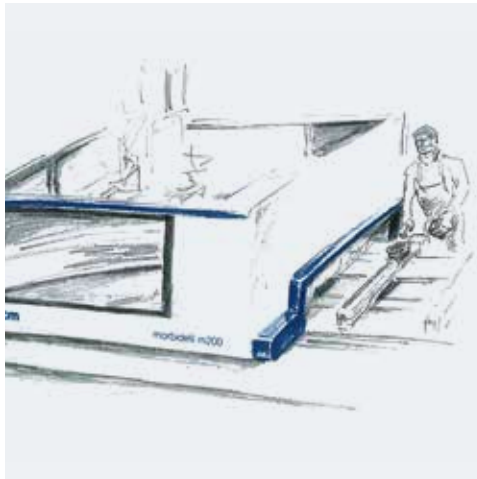

Optimizing the space in your factory thanks to the PRO-SPACE solution.

Accessible and ergonomic 360° all around, no floor obstructions: all the components are within the base.

Total safety and freedom to load large panels (as wide as 2200 mm) due to the work table being entirely accessible.

MINIMUM OVERALL DIMENSIONS MAXIMUM SAFETY AND FLEXIBILITY

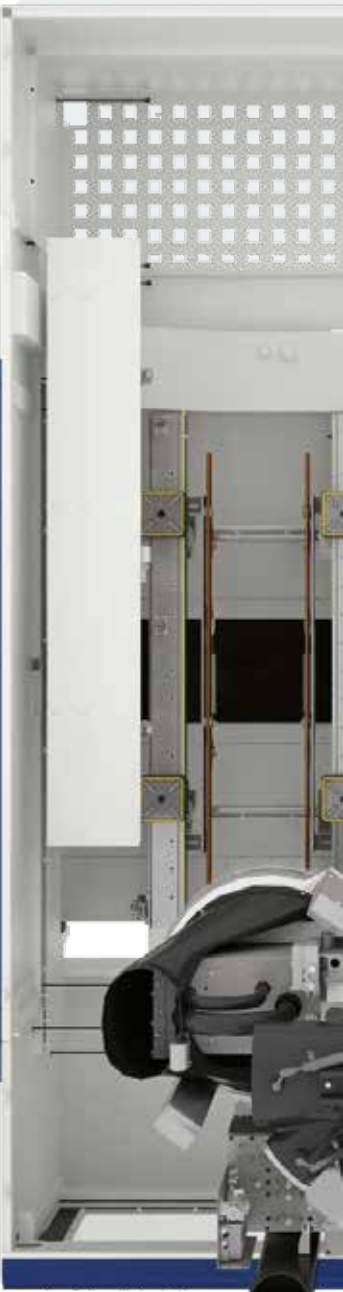

“PRO-SPACE” PROTECTIONS

Loading zone completely free to reduce the space occupied to the minimum. The absence of perimeter protections facilitates the work table access on all the sides of the machine.



morbidelli m100/m200

numerical controlled machining centres

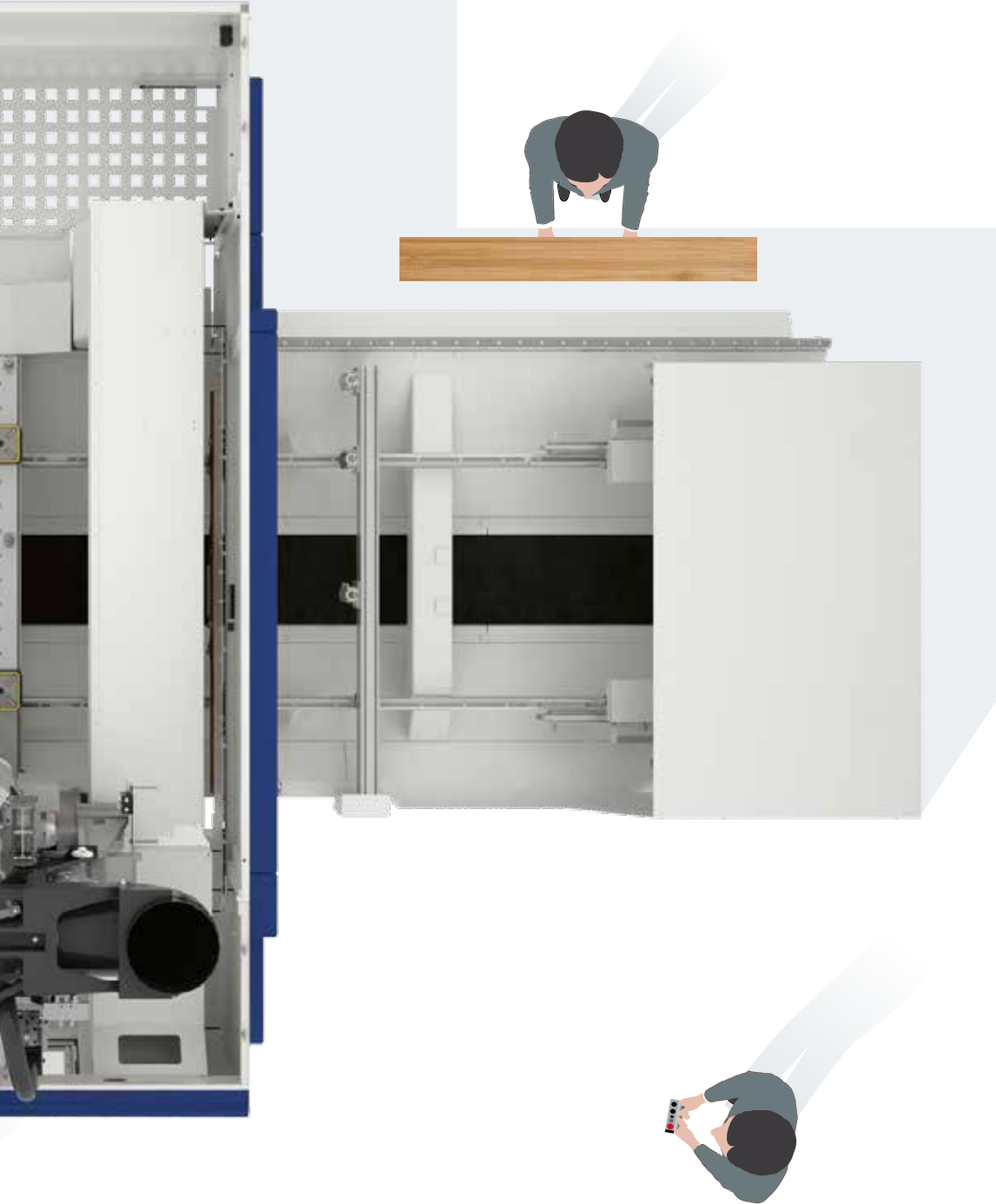

SAFETY SYSTEMS

GUARANTEED SAFETY: BUMPERS PROTECTIONS

Fully safe machining with the bumpers safety system with lock the machine in case of accidental contact with the operator.



MINIMUM OVERALL DIMENSIONS MAXIMUM SAFETY AND FLEXIBILITY: PRO-SPACE PROTECTIONS

Loading zone completely free to reduce the space occupied to the minimum. The protections allow the machine to be used with a feed speed up to 25 m/min in X direction. The absence of perimeter protections facilitates the work table access on all the sides of the machine.

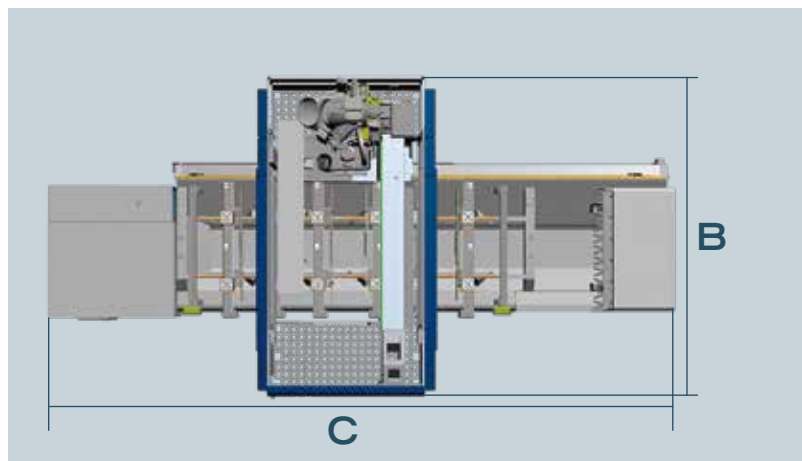

TOTAL FREEDOM AND HIGH PRODUCTIVITY: PRO-SPEED PROTECTIONS

Protection system for the machine use to the maximum speed of 60 m/min. When the operator enters into the loading area, which is delimited by the front photocell barrier, the machine automatically reduces the speed; when the operator leaves the loading area the system restore the maximum speed.

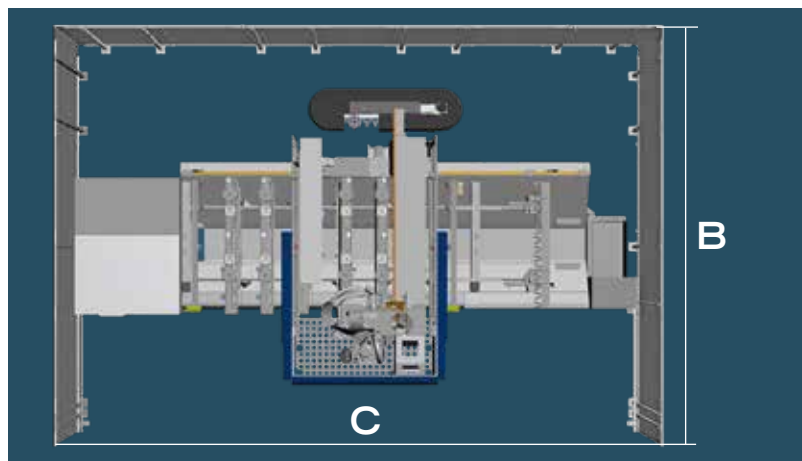

OVERALL DIMENSIONS

morbidelli m100/m200

numerical controlled machining centres

		A	B		C	
			PRO-SPACE	PRO-SPEED	PRO-SPACE	PRO-SPEED
MORBIDELLI M100 WORK TABLE						
Working area 3110 x 1320	mm	2650	3156 (4156*)	4720	6715 (7065*)	7300
Working area 3710 x 1320	mm	2650	3156 (4156*)	4720	7315 (7665*)	7900
Working area 5510 x 1320	mm	2650	3156 (4156*)	4720	9115 (9465*)	9700
Working area 3110 x 1620	mm	2650	3456 (4456*)	5020	6665 (7015*)	7300
Working area 3710 x 1620	mm	2650	3456 (4456*)	5020	7265 (7615*)	7900
Working area 5510 x 1620	mm	2650	3456 (4456*)	5020	9065 (9415*)	9700
MORBIDELLI M200 WORK TABLE						
Working area 3110 x 1620	mm	2820	3562 (4562*)	5020	6670 (7020*)	7300
Working area 3710 x 1620	mm	2820	3562 (4562*)	5020	7270 (7620*)	7900
Working area 5510 x 1620	mm	2820	3562 (4562*)	5020	9070 (9420*)	9700

* It includes the operating area

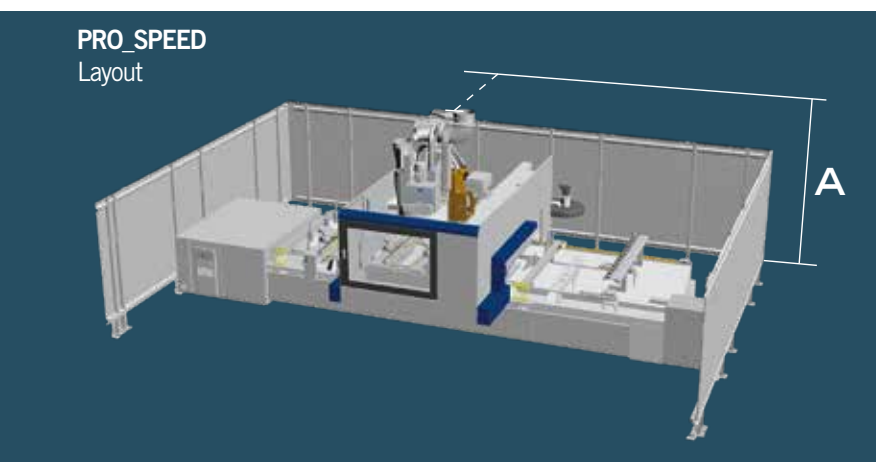
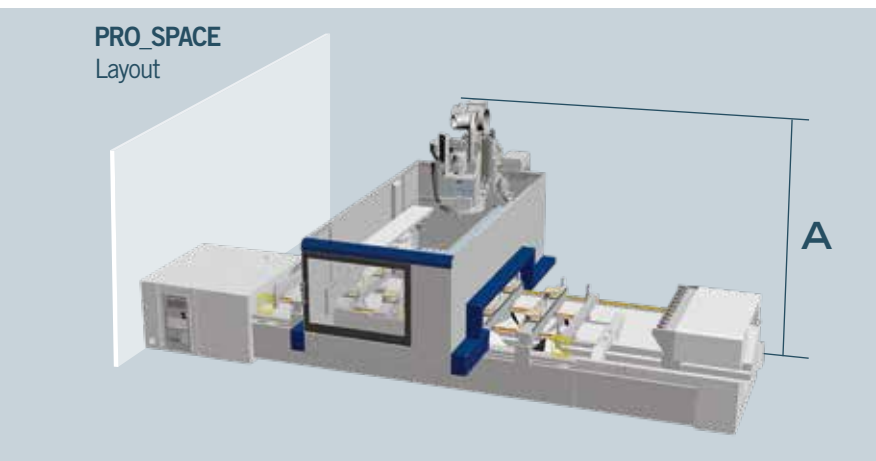

5 AXES AT HAND



ALL TOP QUALITY

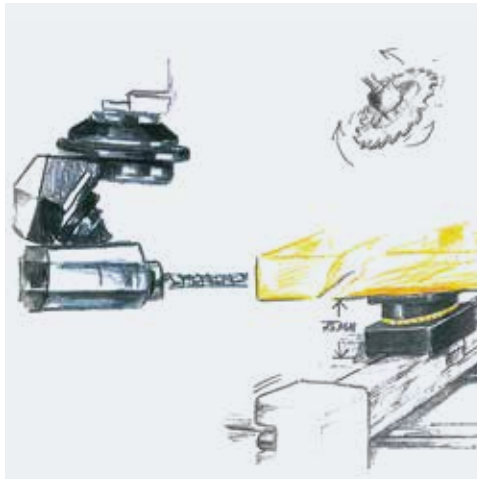

Unique to the market: up to 4 types of units to fit different working groups.

Unrivalled finishing with new direct drive **JQX** (Just **Q**uality **eX**treme) 5-axis electrospindle.

Reduced maintenance, thanks to the **RO.AX** (Rotoaxial spindle technology) drilling bits. It is recommended only after more than 1000 hours of work.

60% of time saved on drilling cycles with the new drill-bits designed to guarantee the best effectiveness on all types of material.

MACHINING UNIT: DRILLING UNIT

The higher drilling capacity in its category up to 21 vertical spindles, 12 horizontal spindles and independent blade unit.

INDESTRUCTIBLE AND WITH LOW MAINTENANCE

The sturdiness of drilling heads is proven by the reduced maintenance costs: it is recommended only after more than 1000 hours of work.

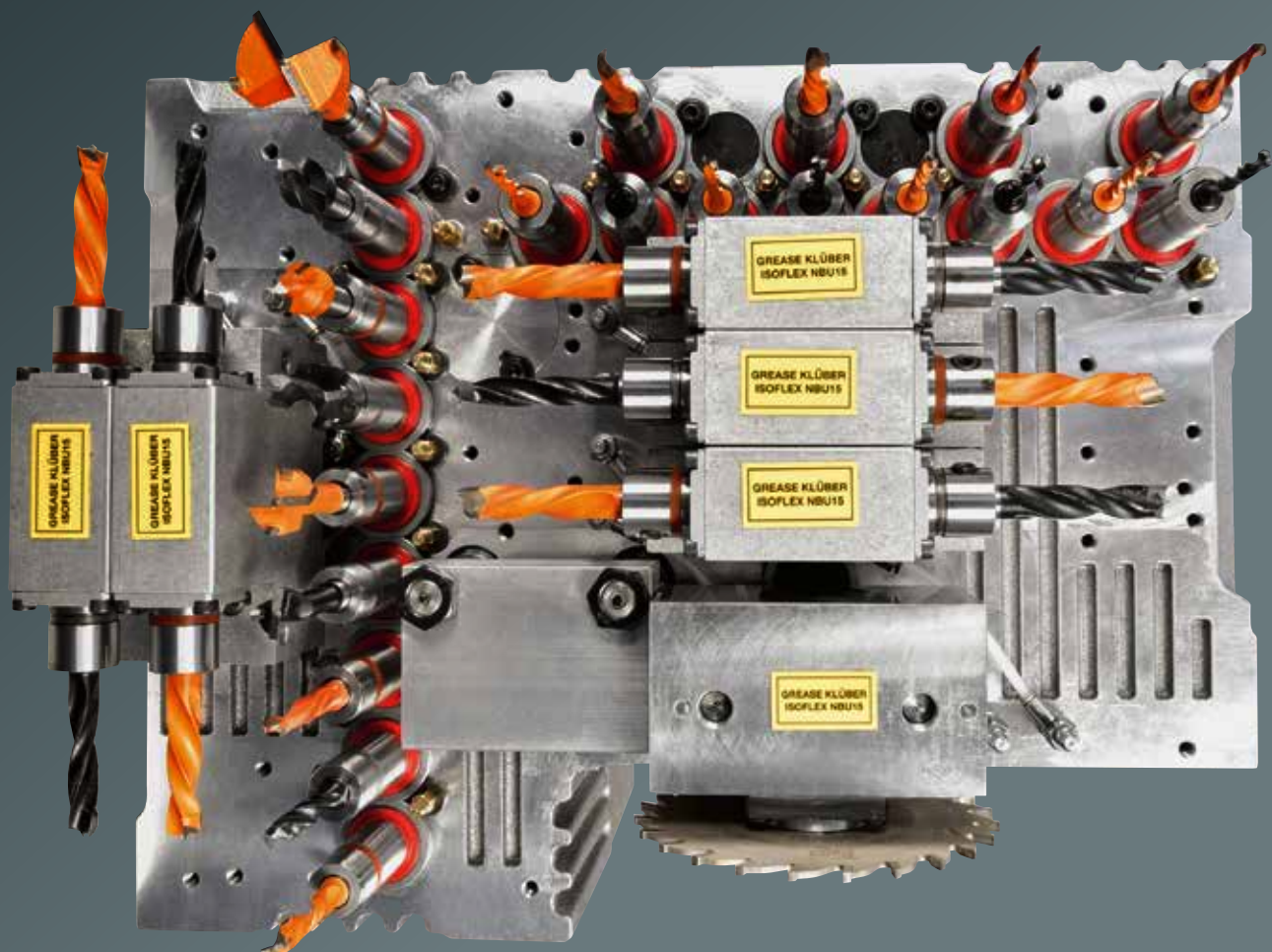



60% of time saved on drilling cycles with the new drill-bits designed to guarantee the best effectiveness on all types of material.

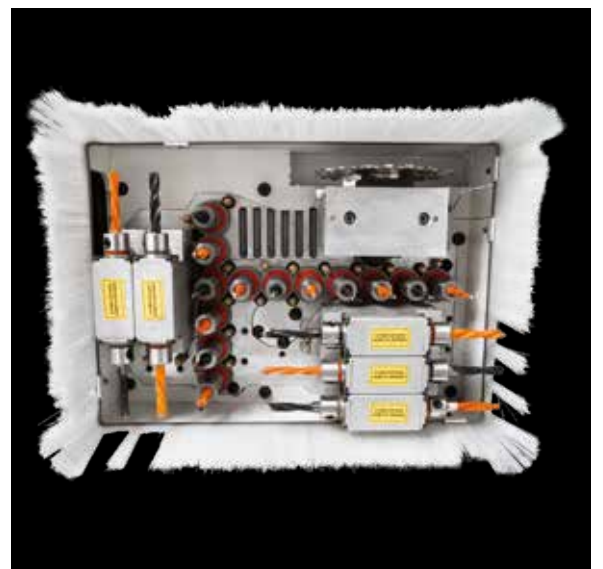

THE PERFECT DRILLING



RO.AX SPINDLE

Zero play during machining with the new RO.AX technology (Rotoaxial spindle technology), the most efficient spindle on the market with rotation speeds up to 8000 rpm.

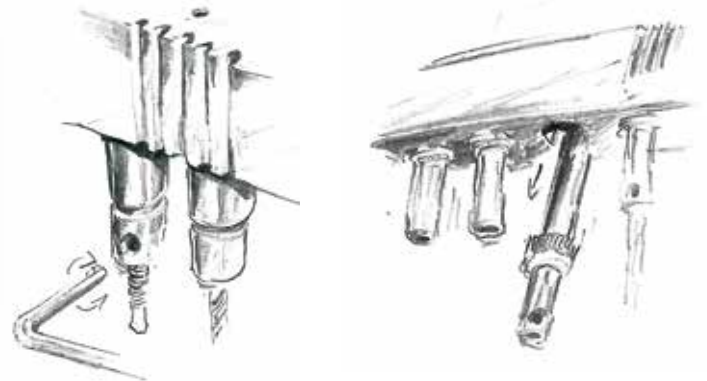
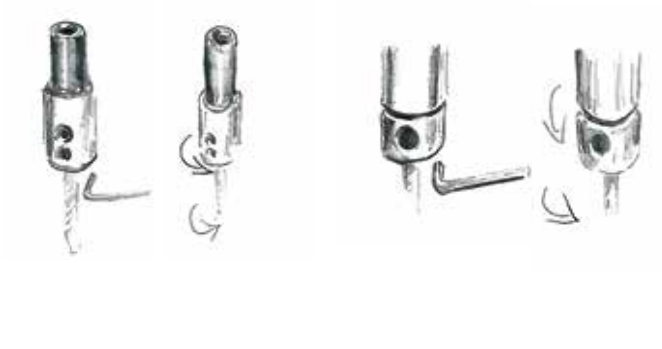

High performance drilling units thanks to the spindles with innovative design. The new drilling spindle offers optimal solutions to achieve the highest quality of finishing and the maximum speed of the whole execution:

- **more than 50% increase in rigidity:** rod spindle diameter from 20 mm
- **reduction of vibrations and guaranteed drilling quality on all materials:** rod spindle guide system with special roll bearings
- **lower operation noise and more rigidity:** absence of radial friction between spindle and rotating bearings
- **reduced maintenance costs:** new system to disassemble the spindle
- **more reliability:** less components employed



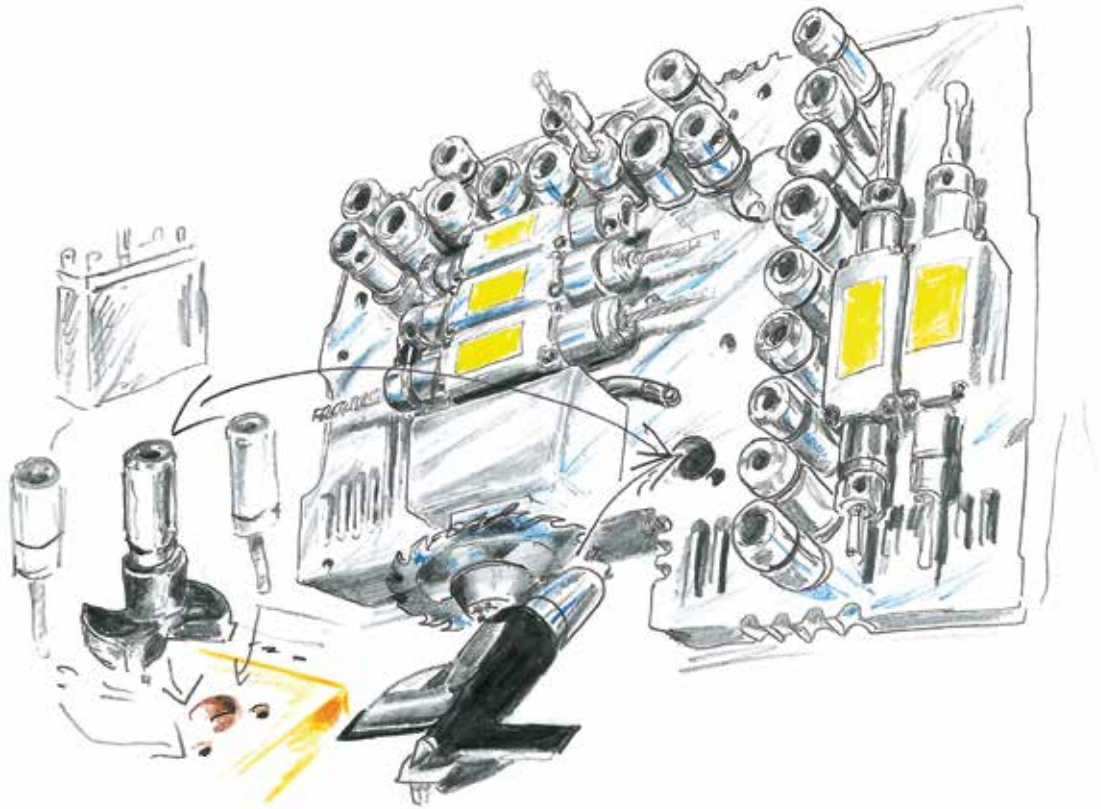

**HINGE DRILLING:
ONE STEP WORTH THREE!**

Possibility to carry out 3 simultaneous drillings with a single head integrated in the main drilling unit.

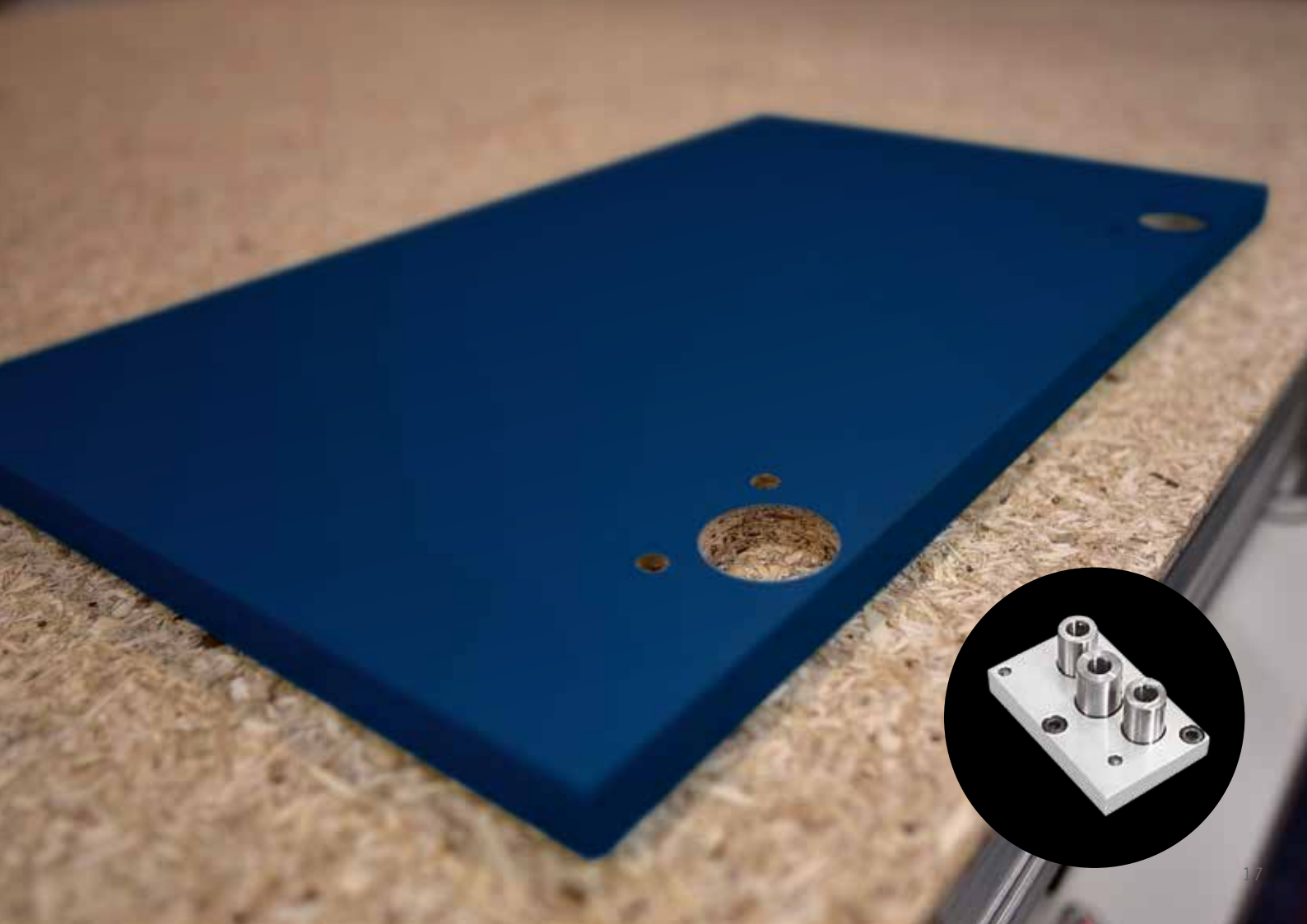

UNIVERSAL, HIGH SPEED ROTATION

TO PRODUCE OBJECTS
WITH ANY KIND
ON SHAPE ON ANY
KIND OF MATERIAL

JQX ELECTROSPINDLE

Very high finishing quality with the **JQX** (Just Quality **eXtreme**) 5-axis electrospindle, with direct drive and up to 12 kW power, which ensures total absence of vibrations even with large material removals at high speeds.

The lightweight structure and the excellent price/quality ratio make this electrospindle ideal for those looking for a flexible and practical product but with high level performance.



morbidelli m100/m200

numerical controlled machining centres

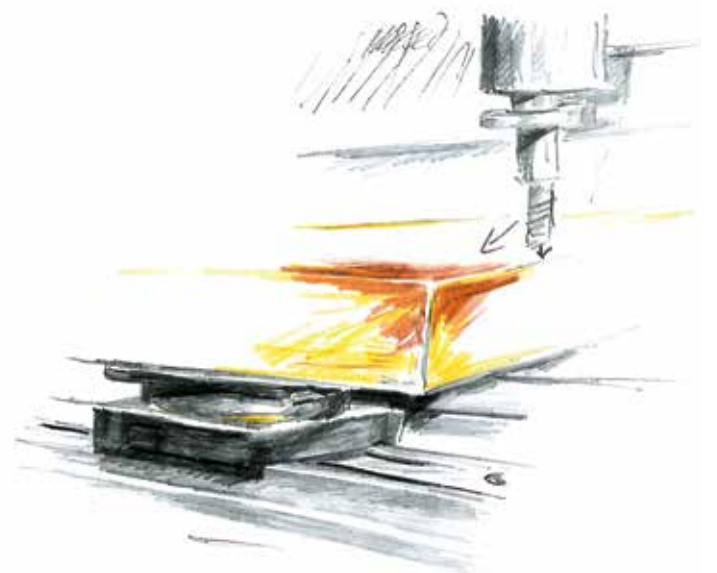

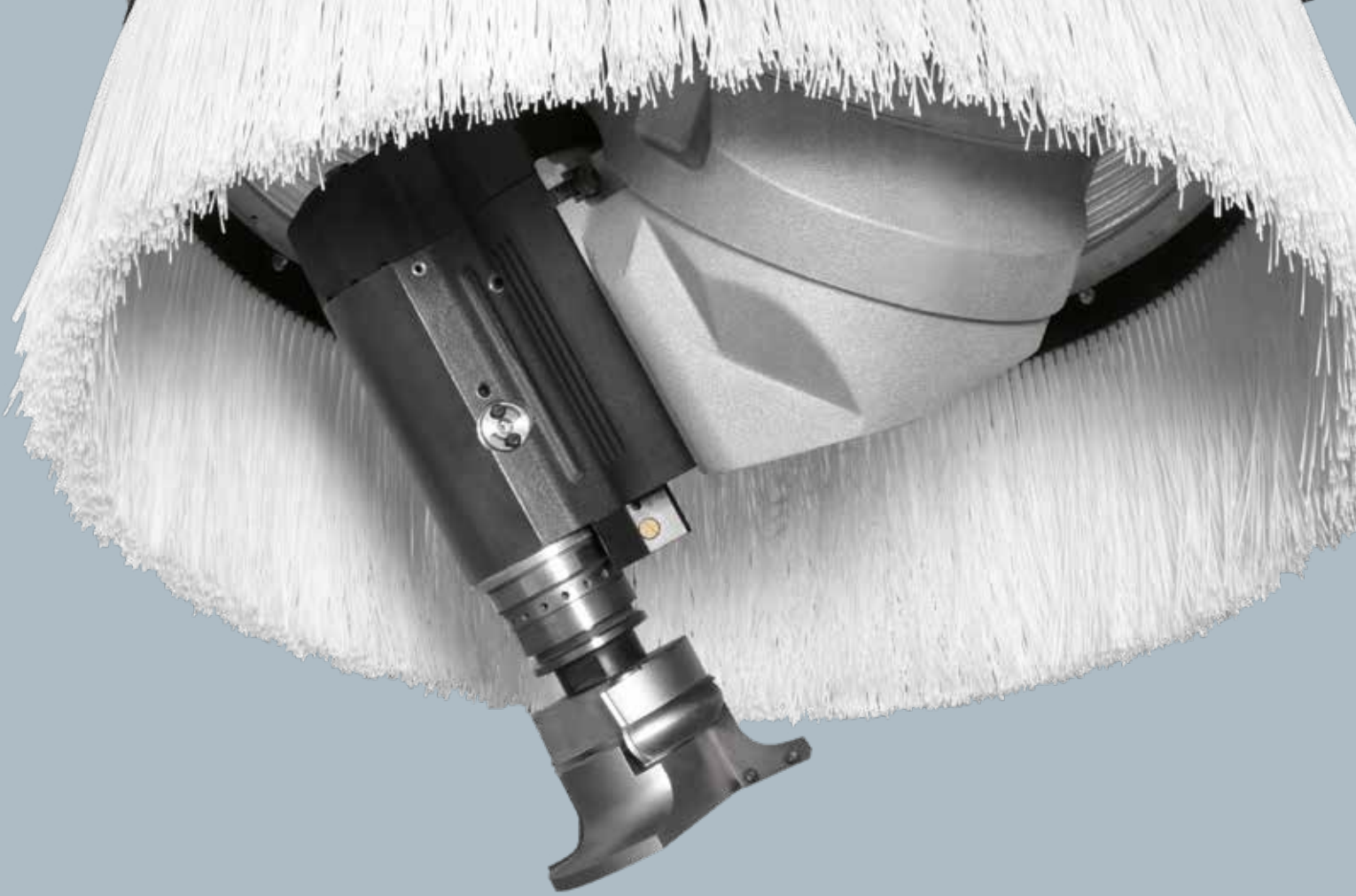

POWERFUL AND COMPACT: PRISMA KT/KS ELECTROSPINDLE

High performance with Prisma KT and KS electrospindles, the top in its category in terms of power and torque at all RPMs. High quality finish even on heavy machining with the exclusive **TTS (Total Torque System)** locking system, that provides the spindle with the rigidity of a 3-axis unit.

SUPERIOR TECHNOLOGY FOR MACHINING WITH 5 AXES: PRISMA ELECTROSPINDLE

Reduced maintenance, maximum flexibility and optimal finishing quality with the BEL.TECH technology (Belt technology system), the belt transmission system which eliminates vibration and heat from tools to the motor. This system (in use on the spindle for machining metals) due to the **compact structure**, allows easy operations in limited spaces.

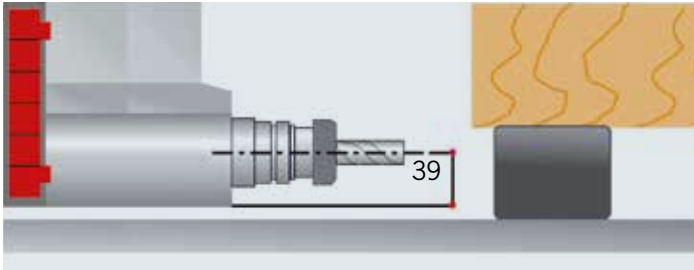

5-axis machining unit geometry allows it to operate at angles of up to 10° below the work piece supporting surface.

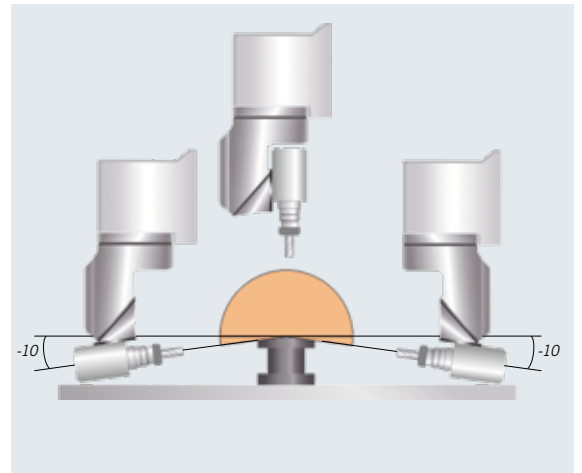



Optimal machining precision with the 3-axis electrospindle up to 24.000 rpm.

Easy grooves machining on the sides of the furniture thanks to the integrated blade unit.

Production of doors and other horizontal machining that require heavy duty routing (grooves, hinge or lock recesses), with high precision and speed, by means of the two outlet horizontal spindle.

Higher efficiency and working time reduction with the 4,5 kW additional routing unit.

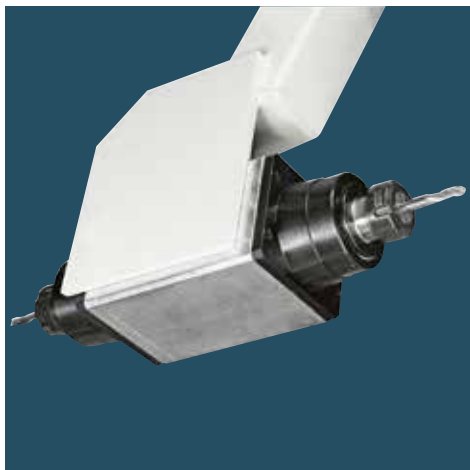

DRILLING AND DOWELLING IN A SINGLE OPERATION: HI.LOCK DEVICE

Work pieces finished and ready for the assembling with the HI.LOCK (High locking system) dowel insertion unit, the device that can manage the insertion of dowels on a machining centre.

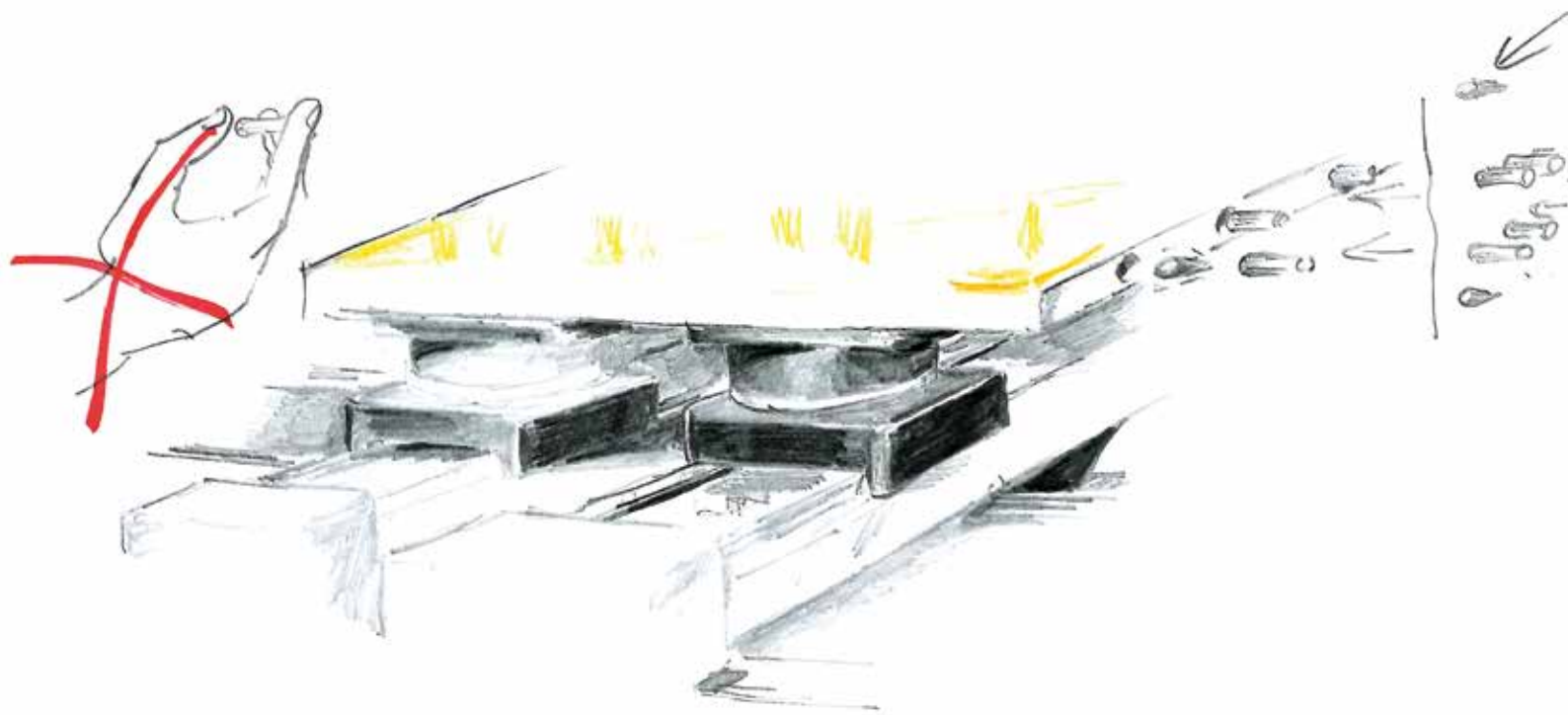

Optimisation of productivity with no more time wasting for cleaning operations, thanks to the use of glue capsules, contrary to traditional dowelling devices where it is necessary to remove the remaining drying glue from the various components after a temporary production-stop.

Glue capsule



REDUCTION OF WORKING TIMES

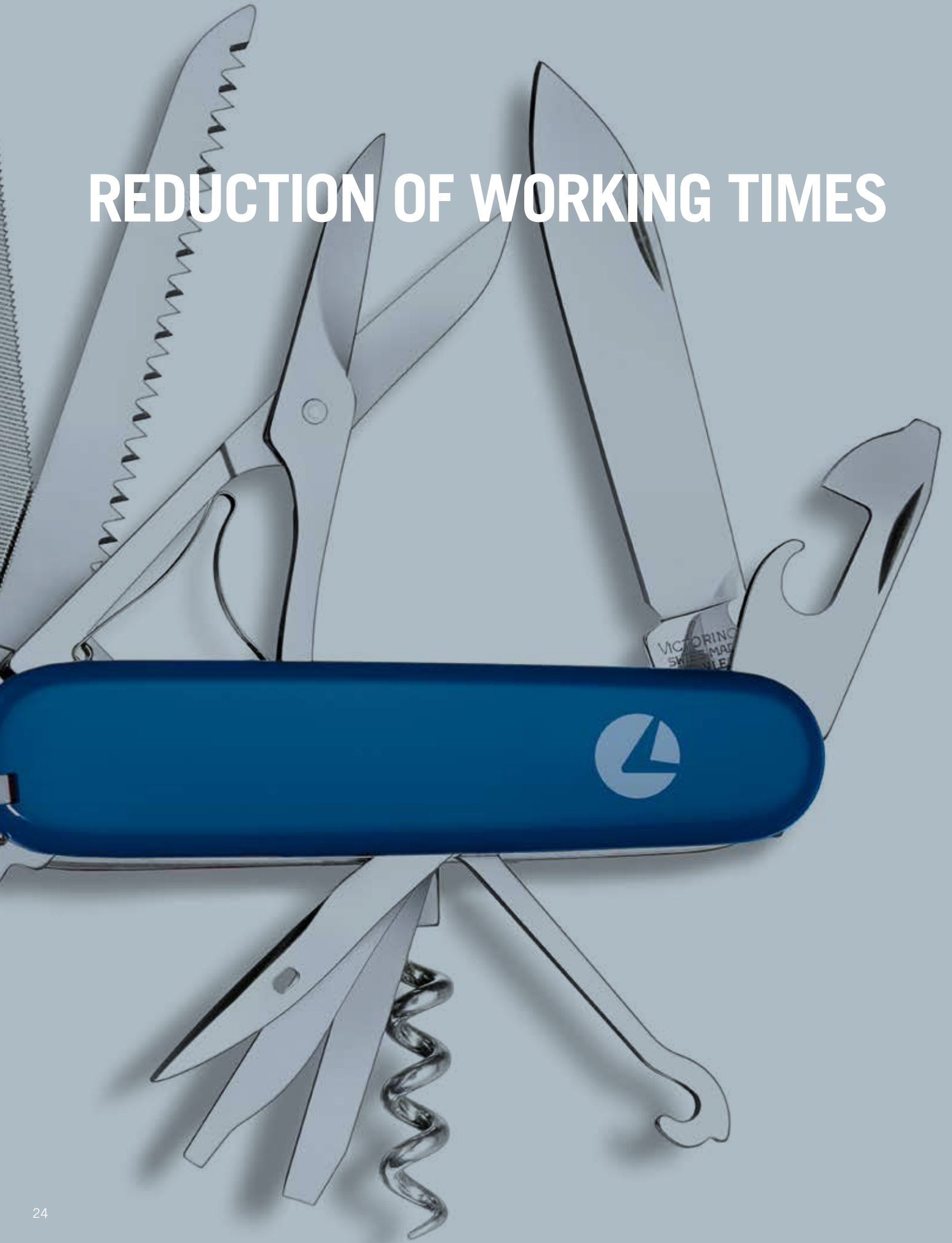

ALL FASTER

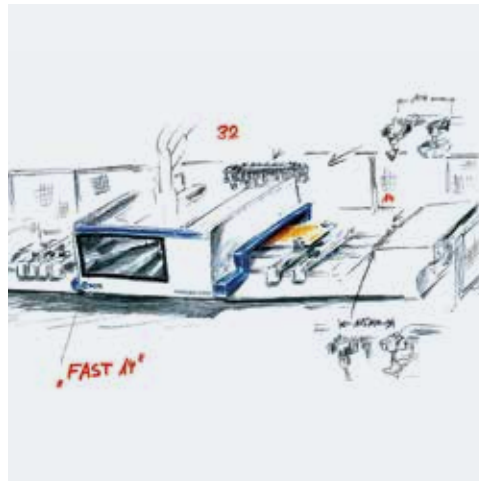

Beyond imagination, up to 60 tools always available on board make the machine the best in its class.

Less than 15" for the tool change with the 14 position **FAST** tool changer.



ALL AT YOUR SPINDLE FINGERTIPS!

UP TO 60 TOOLS ALWAYS AVAILABLE ON BOARD
MAKE THE MACHINE THE BEST IN ITS CLASS

NO IDLE TIME for the tool change from a machining process to another one with the 14 position **FAST** tool changer.

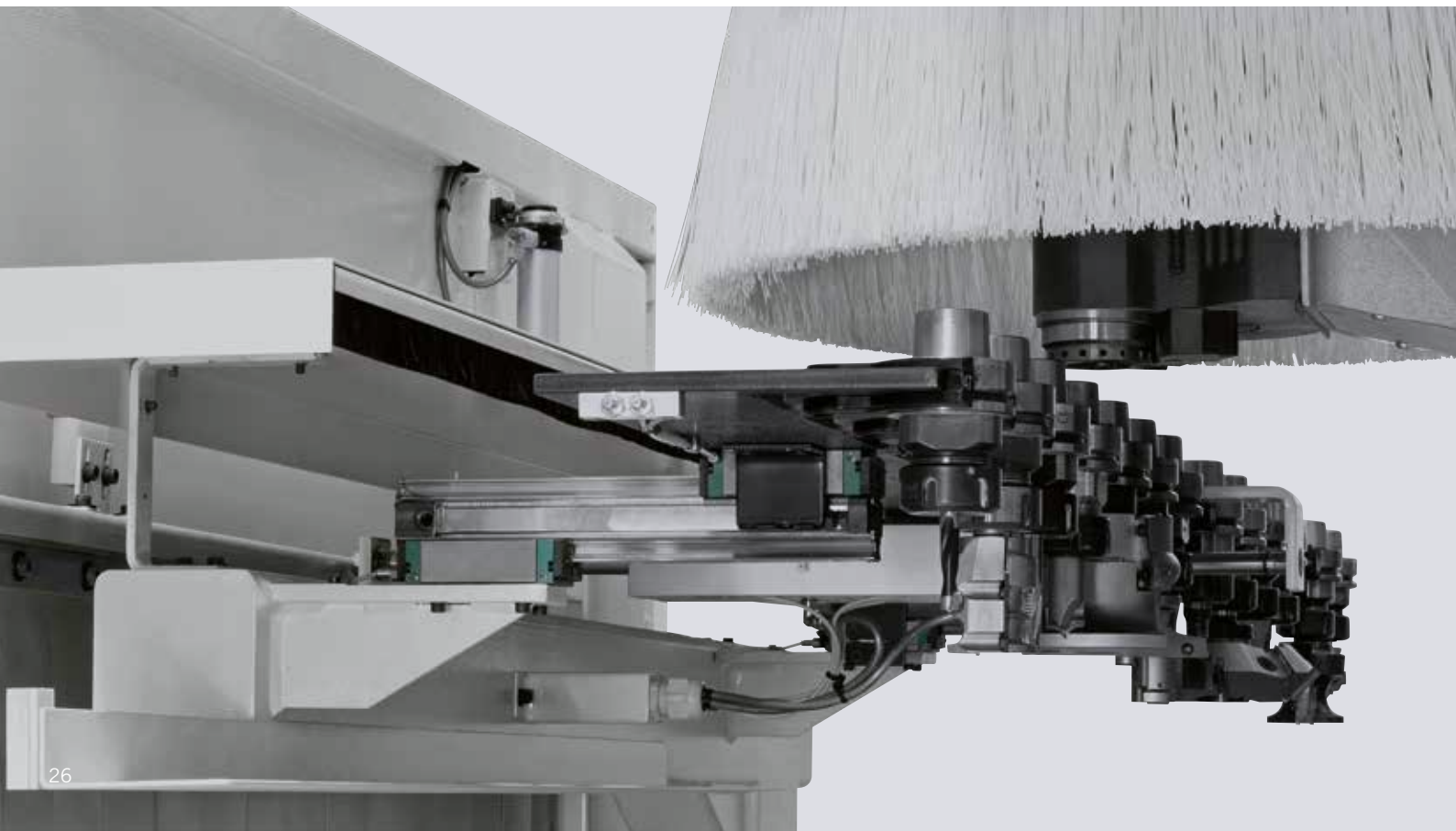

morbidelli m100/m200

numerical controlled machining centres



Wide range of tools available to the operator with the rear tool changers up to 32 positions.

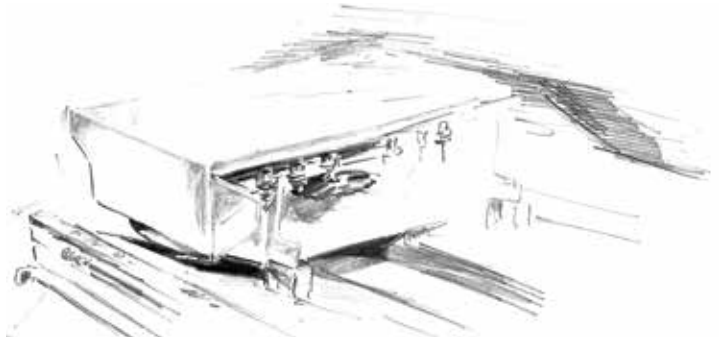

TRB side tool changer with 11 or 14 positions.



EVERYTHING YOU ALWAYS DREAMED OF A CNC MACHINING CENTRE BUT WERE TOO AFRAID TO ASK

INIFINITE WAYS OF BEING

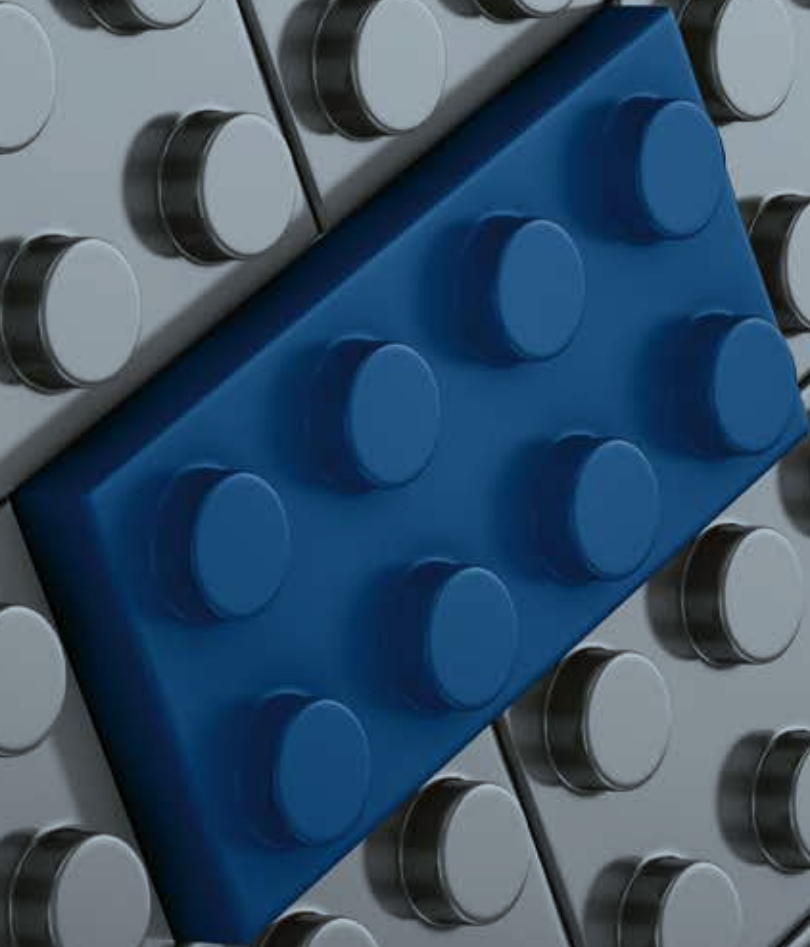

ALL FLEXIBLE

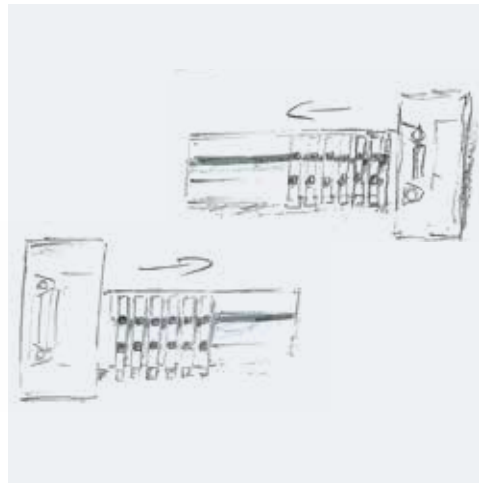

The machine is perfect for all types of materials: from wood to plastic, from panel to furniture, from kitchen doors to windows. **The right solution configured for all your needs** and your investment plan.

Zero idle times for set-up operations and no compromise for the machine performance with the **versatility** and free **configurability** of the **TV FLEXMATIC** work table.

No limit for the work piece machining with thickness from 180 and 250 mm on 75 mm vacuum pods.

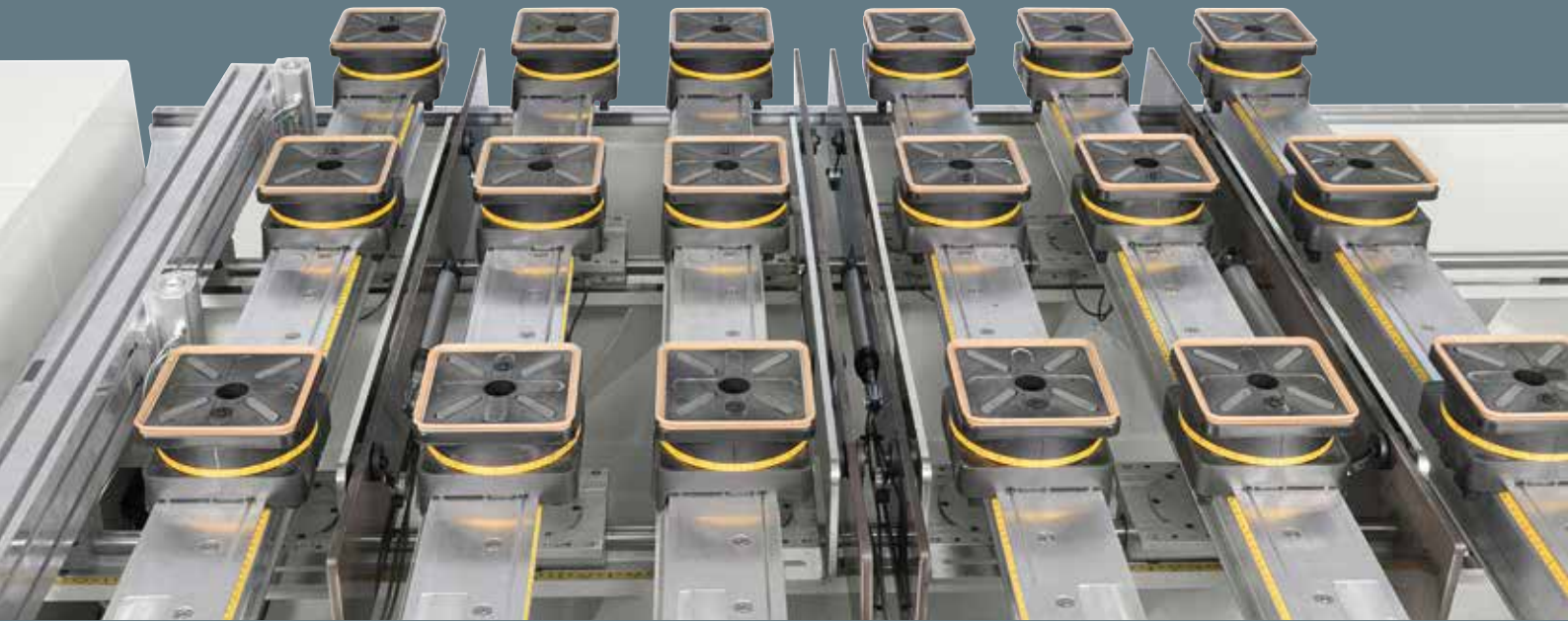

TOTAL CUSTOMISATION: TV FLEXMATIC RAILS WORK TABLE

Automatic work table that allows the management up to 6 vacuum pods on a single rail, according to the dimensions and shape of the work piece to be machined, in order to always have the best holding without risks of collision.

Available also with manual version (**TV FLEX**).

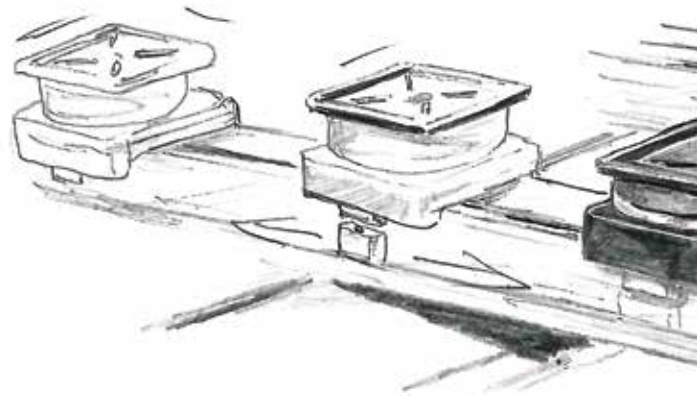
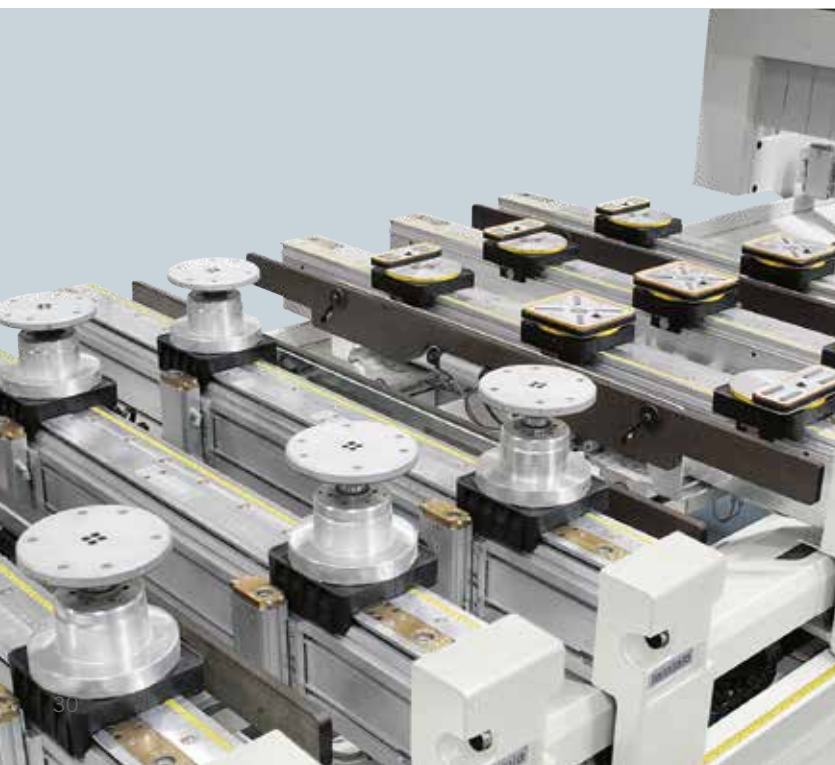

morbidelli m100/m200

numerical controlled machining centres



It is possible to add or remove vacuum pods or clamps with a simple movement of the hand; the number and the position are automatically detected.

No problem for the sliding of vacuum pods or clamps thanks to the blowers positioned along the whole rail that guarantee a constant cleaning.

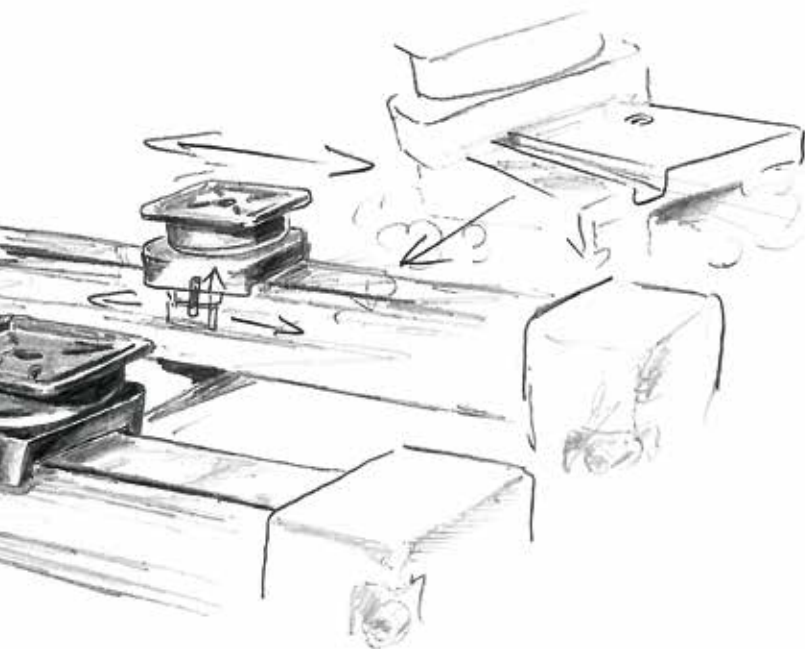

From a single panel can be obtained more elements and automatically re-position them to carry out all machining without interrupting the production cycle; at the end the work pieces are returned to the initial position to facilitate the unloading from the work table.

TV FLEXMATIC RAILS WORK TABLE

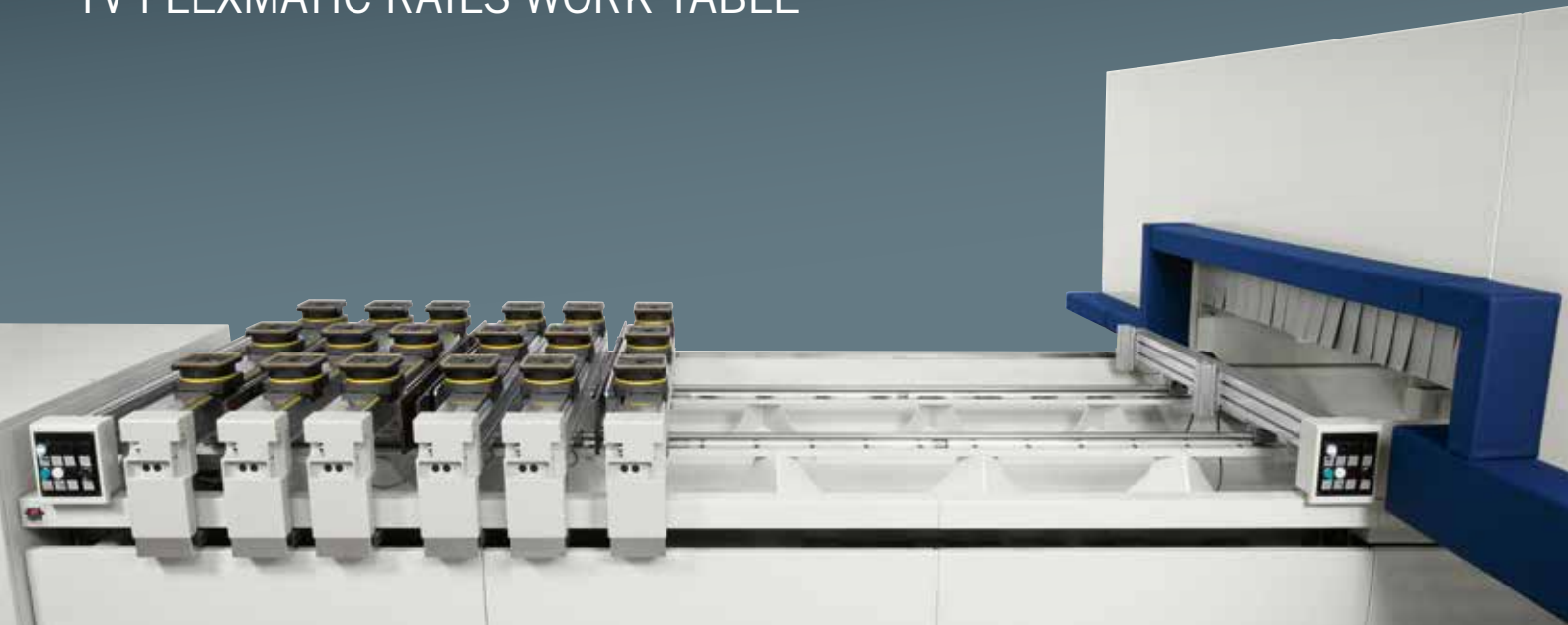

NO LIMITS ON RAILS POSITIONING: TOTAL COVERAGE OF THE WORK TABLE

IDEAL FOR LARGE SIZE PANELS

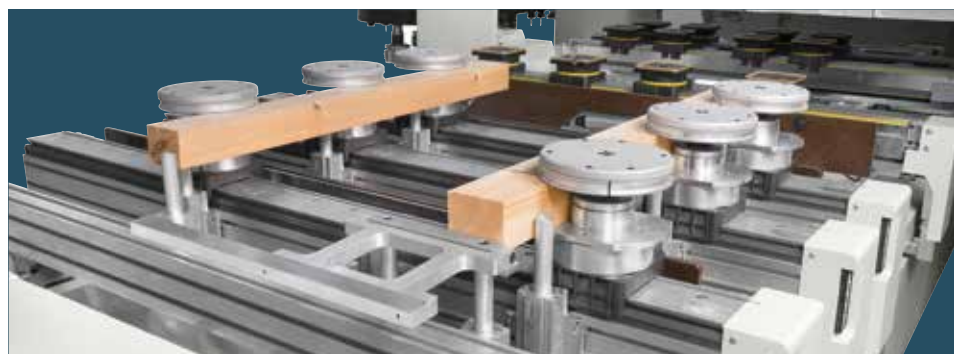

Simple and quick work table set-up also for the manual version.

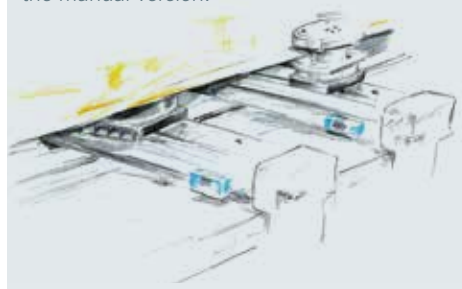

morbidelli m100/m200

numerical controlled machining centres

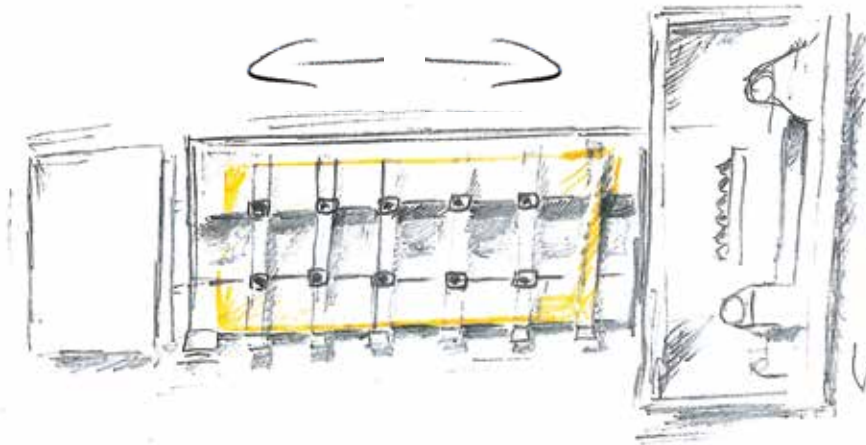
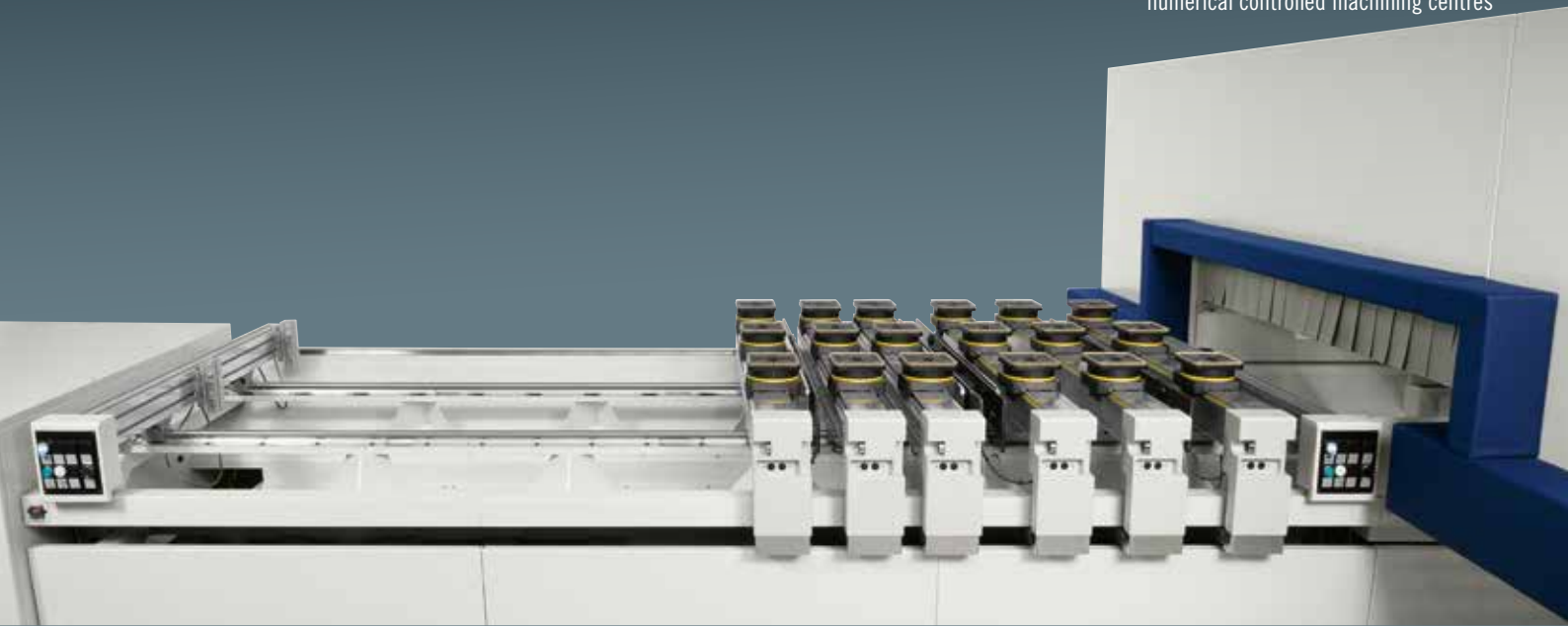

Comfortable pushbutton to have at your fingertips all the necessary commands for the programs execution.



Easy positioning of heavy work pieces and large panels with the lifting support.



VERY HIGH FLEXIBILITY: MULTI-FUNCTION WORK TABLE

Extremely stiff work table made of extruded aluminium, designed to maintain a perfect planarity over time, even after repeated mechanical stresses. It is ideal also for nesting machining.

Optimal work piece holding with the high capacity vacuum up to 1200 m³/h (50 Hz).

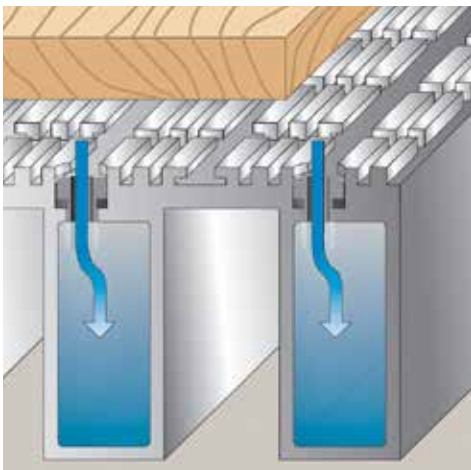

morbidelli m100/m200

numerical controlled machining centres

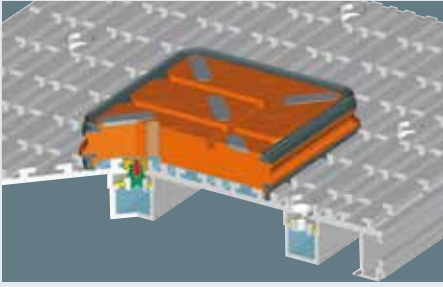

Easy and quick positioning of locking accessories such as MPS vacuum pods and the practical MODULSET system with the surface channels structure.

It is possible to fix custom references thanks to the exclusive "T-shaped" grooves available on the work table.

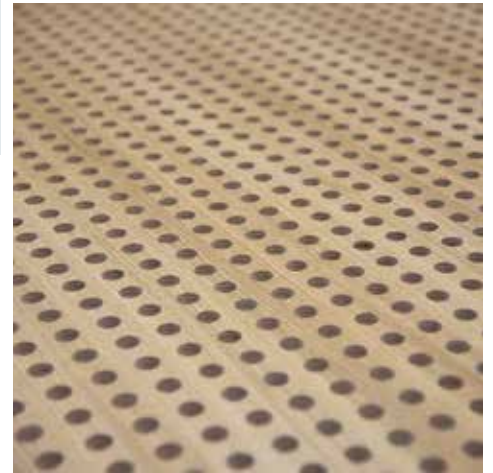



DEVICES FOR PARTICULAR APPLICATIONS

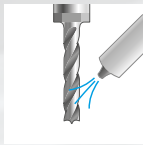

Air blower on electrospindle

For generic applications.

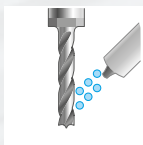

Ionized air blower on electrospindle

It is suitable to eliminate the electrostatic charges due to the cut material, making easier the shavings suction (advisable for plastic materials machining).



Air blower with microlubrication

Air blower with very little oil quantity for the tool lubrication and cooling when used on coated panels.



Guides protections, X-Y axes

By means of dedicated cleaning and protection system, it allows the machining also on abrasive materials (this device is compulsory for machining on plasterboard material).

DEVICES FOR OTHER MATERIALS

A range of dedicated heads for the machining of non-wood and advanced materials, such as plexiglas, plastics, alucobond, aluminum, polyurethane foams and honeycomb cardboard.



THE MATERIALS



EVERYTHING YOU ALWAYS DREAMED OF A CNC MACHINING CENTRE BUT WERE TOO AFRAID TO ASK

SWEEP AWAY THE WORRIES

ALL CLEAN

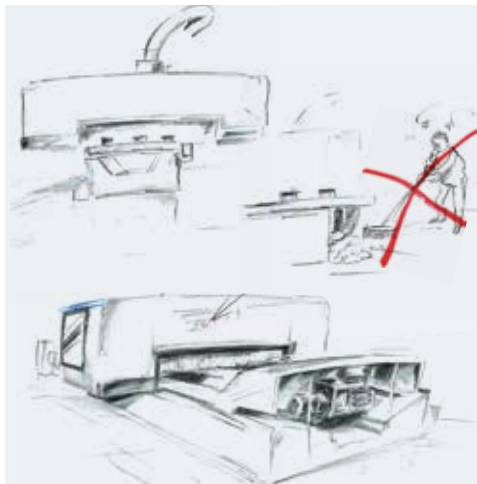

No problem with dust or shavings thanks to the intelligent solution of the dust collection box located in an ergonomic position.

Free space on the floor with the vacuum pump integrated in the machine base.

SPACE? NO PROBLEM!

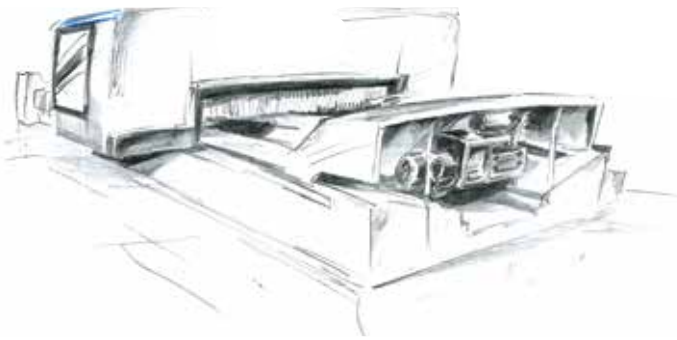

Free access without obstacles on the floor, cable-holder chain and vacuum pump integrated in the machine base.

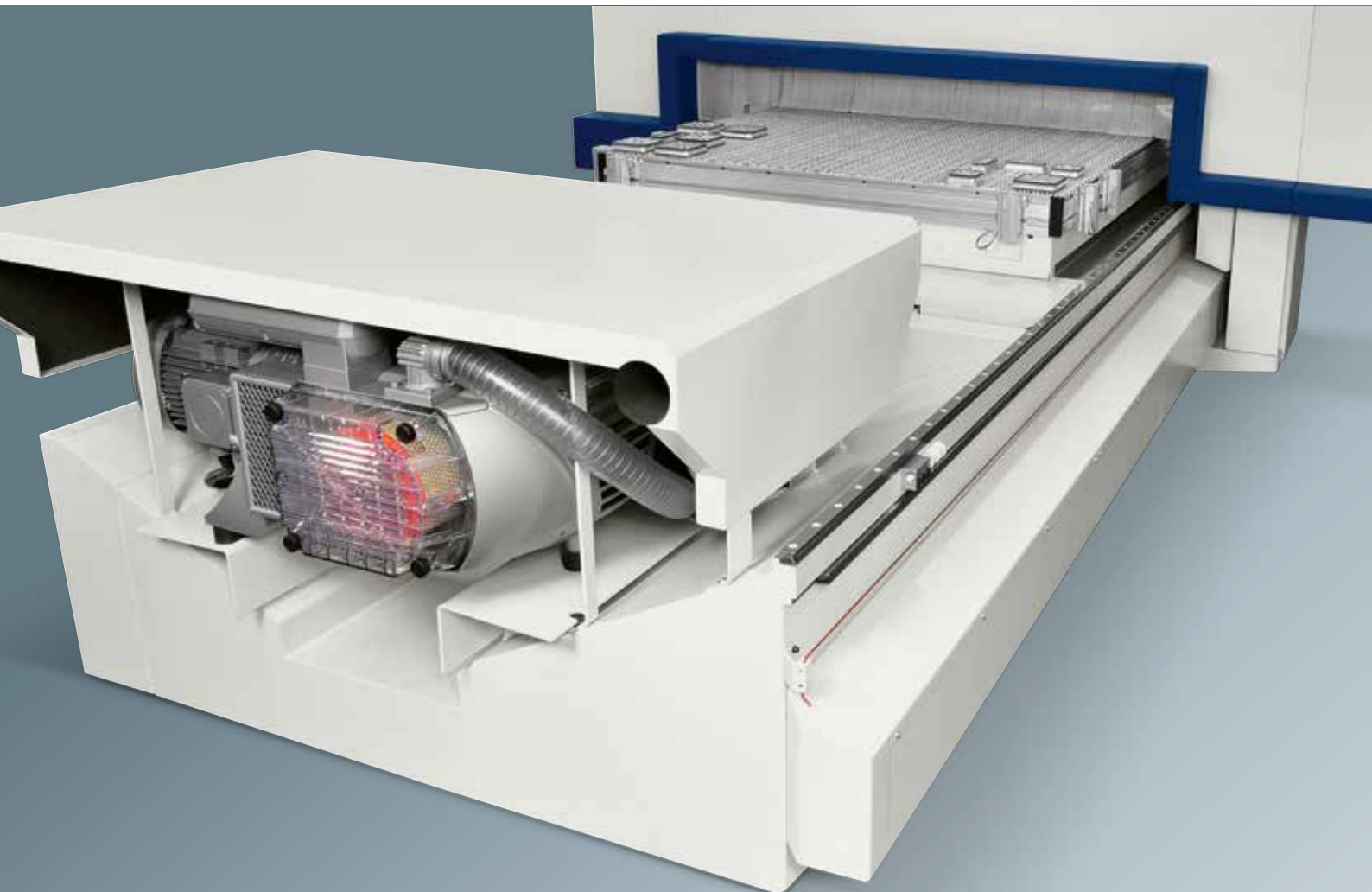

morbidelli m100/m200

numerical controlled machining centres



Rapidity and ergonomics to equip and do maintenance to the operating group thanks to the practical frontal opening.

No problem with dust or shavings thanks to the dust shavings conveyor belt equipped with exhaust outlet and the dust collection box located in an ergonomic position.



EVERYTHING YOU ALWAYS DREAMED OF A CNC MACHINING CENTRE BUT WERE TOO AFRAID TO ASK



READY IN 1 DAY

ALL READY



1 technician, 1 day and the machine is up and running!

MAESTRO SUITE

THE SOFTWARE THAT SIMPLIFY THE WORK

CAD/CAM programming software to design all the production processes.

Developed in Windows® environment it ensures easy programming with an advanced, simple and intuitive sketching environment that features all the tools necessary to design the parts, their layout on the work table, tools management and the relative machining operations. All the procedures are contained in a perfectly integrated and high performance software.

TO EACH TECHNOLOGY HIS SCM SOFTWARE



MAESTRO APPS - Unique know-how

Maestro apps is a library of programming functions that are always available and easy to use, developed by SCM for the production of parts for doors, windows, stairs, furniture and furnishings.



MAESTRO CABINET - Unique in the creation of furniture

This application is designed for the home and office furniture sector to design furniture and program cabinet production step by step.

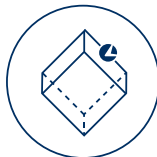

MAESTRO 3D - Unique in the creation of 3D objects

The module integrated in the Maestro suite is designed to program three dimensional objects on 5-axis machining centres.



MAESTRO NEST - Unique nesting process

The module integrated in the Maestro suite provides all the functions necessary to manage the “nesting” process: from a simple “rectangular” piece to the most varied and complex “free form” geometrical shapes.

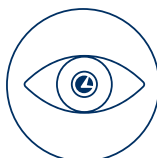

MAESTRO PRO VIEW - Unique 3D display

3D Simulator that allows users access to a three dimensional model of their machine in their office and view the operations that will be carried out during the production in advance on their PC.

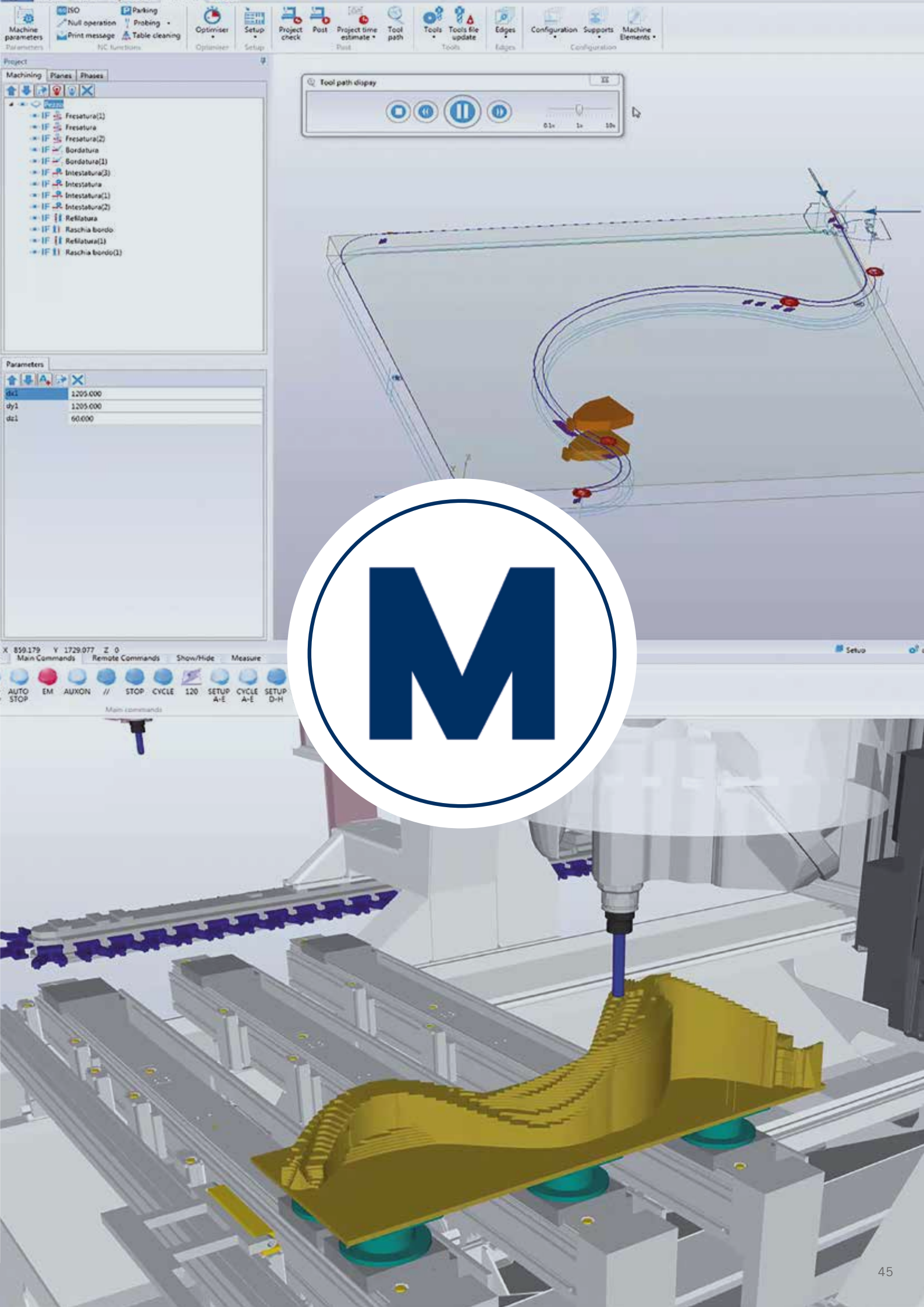

M

TECHNICAL DATA

MORDIBELLI		M100	M200
AXES			
Vectorial speed X-Y axes "PRO-SPACE" version	m/min	56	56
Vectorial speed X-Y axes "PRO-SPEED" version	m/min	78	78
Z axis panel passage	mm	180	250
ROUTING UNIT			
Motor power (max.)	kW (hp)	15 (20,5)	15 (20,5)
Rotation speed (max.)	rpm	24000	24000
Available tools on tool changer (max.)	places	44	60
DRILLING UNIT			
Independent vertical spindles (max.)	n.	21	21
Independent horizontal spindles (max.)	n.	12	12
Rotation speed (max.)	rpm	8000	8000
Integrated blade in X, diameter	mm	125	125
INSTALLATION			
Exhaust air consumption	m ³ /h	4430	4430
Exhaust air speed	m/sec	25	25
Exhaust outlet diameter	mm	250	250



THE USE OF POWER ONLY WHEN IT IS REQUIRED

SavEnergy allows making things operate only when they are really necessary. It means the machine automatically enters "stand-by" mode when there are no panels to be machined.



The technical data can vary according to the requested machine composition. In this catalogue, machines are shown with options. The company reserves the right to modify technical specifications without prior notice; the modifications do not influence the safety foreseen by the CE Norms.

*Maximum noise levels measured according to the operating conditions established by EN 848-3:2012
Acoustic pressure in process (routing) 81 dbA (measured according to EN ISO 11202:2010, uncertainty K = 4 dB)
Acoustic power in process (routing) 98 dbA measured according to EN ISO 3746:2010, uncertainty K = 4 dB)*

Even if there is a correlation between above mentioned "conventional" noise emission values and average levels of personal exposure over eight hours of operators, these last also depend on the real operating conditions, duration of exposure, acoustic conditions of the working environment and presence of further noise sources, this means the number of machines and other adjacent processes.



THE STRONGEST WOOD ARE IN OUR DNA

SCM. A HERITAGE OF SKILLS IN A UNIQUE BRAND

Over 65 years of success gives SCM the centre stage in woodworking technology. This heritage results from bringing together the best know-how in machining and systems for wood-based manufacturing. SCM is present all over the world, brought to you by the widest distribution network in the industry.

65 years history

3 main production sites in Italy

300.000 square metres of production space

17.000 machines manufactured per year

90% export

20 foreign branches

350 agents and dealers

500 support technicians

500 registered patents

In SCM's DNA also strength and solidity of a great Group. The SCM Group is a world leader, manufacturing industrial

SCM GROUP, A HIGHLY SKILLED TEAM EXPERT IN INDUSTRIAL

INDUSTRIAL MACHINERY

Stand-alone machines, integrated systems and services dedicated to processing a wide range of materials.



WOODWORKING TECHNOLOGIES



TECHNOLOGIES FOR PROCESSING
COMPOSITE MATERIALS, ALUMINIUM,
PLASTIC, GLASS, STONE, METAL

TECHNOLOGIES



equipment and components for machining the widest range of materials.

MACHINES AND COMPONENTS

INDUSTRIAL COMPONENTS

Technological components for the Group's machines and systems, for those of third-parties and the machinery industry.

HITECO

SPINDLES AND TECHNOLOGICAL
COMPONENTS

Les

ELECTRIC PANELS

steelmec

METALWORK

scmfonderie

CAST IRON

scm
woodworking technology

is more



SCM GROUP SPA

via Casale 450 - 47826 Villa Verucchio, Rimini - Italy
tel. +39 0541 674111 - fax +39 0541 674274
morbidelli@scmgroup.com
www.scmwood.com



00L0367193C